

Coarse Bubble Diffuser



Data Sheet



Solid Disc Diffuser – KSD 320

Specifications

Installation drawing

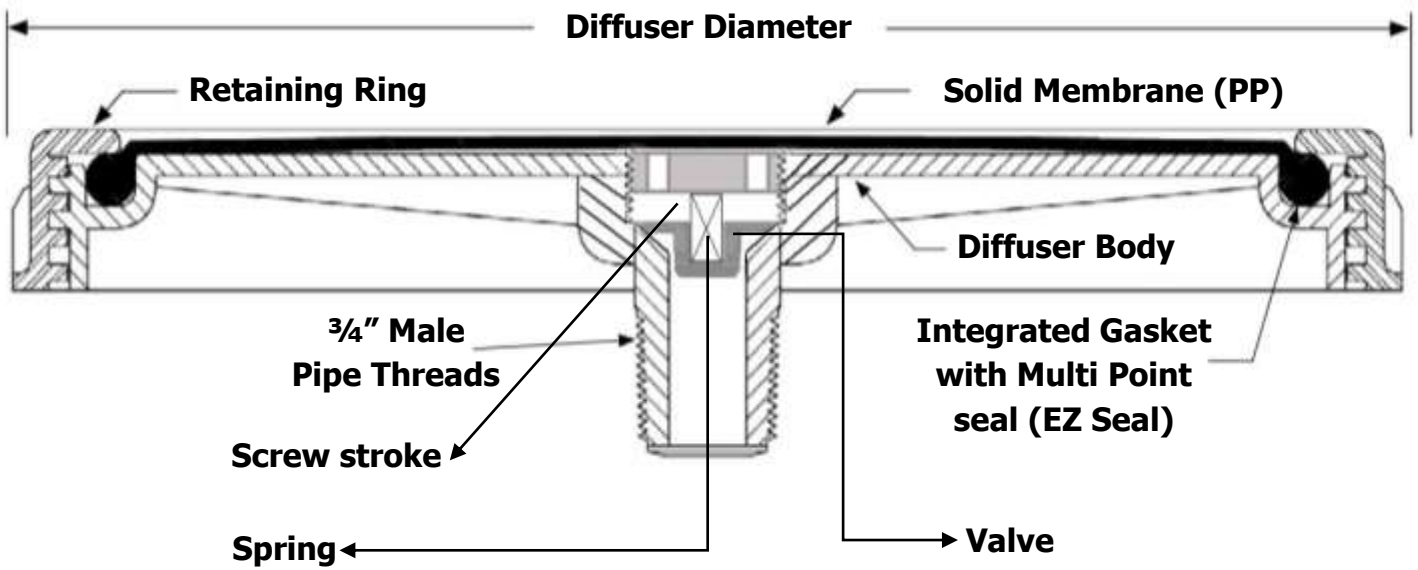

Dimensions

Diameter total/effective	Height	Overall height membrane top of tube	Perforated area	Thread	Check valve
310/242 mm	57 mm	46 mm	0,045 m ²	3/4"	Optional

Material

Rubber Membrane Layer	Body Material
Polypropylene with 30% Glass Fiber (PP + GF30%)	Polypropylene with 30% Glass Fiber (PP + GF30%)



Air Flow

Air flow rates at standard operation conditions	max overload/maintenance air flow rate	Operating temperature	Operation mode	Application
10 - 12 m ³ /h	20 m ³ /h	0 - 80 °C	Intermittent continuous	Municipal wastewater