



AERZEN

POSITIVE DISPLACEMENT BLOWERS

Aerzen positive displacement blower units with three-lobe rotors and internal pulsation cancellation intake volumes from 30 m³/hr to 15.000 m³/hr



**AERZENER MASCHINENFABRIK
GMBH**

Technological advance for the future

The Aerzener Maschinenfabrik GmbH have been manufacturing Positive Displacement Blowers since 1868. They are amongst the oldest and largest manufacturers worldwide and are the Market Leader in Europe. Technical competence, an experienced work force plus a constant dialogue with the operators ensure that Aerzen and our customers stay at the forefront of technical development.

With the development of the Delta Blower Packages, the increasing demands of the market have been achieved.

Delta Blower stands for:

- Aerzen blower stages with integrated pulsation cancellation
- A concept gained from 30 years of blower packages production
- Minimal surface area required for installation
- Maintenance-free drive components
- Discharge silencers, free of absorption material
- Easy accessibility
- Quiet - low noise emission
- Energy efficient therefore environmentally friendly to use
- Quality Control certified acc. to DIN ISO 9001

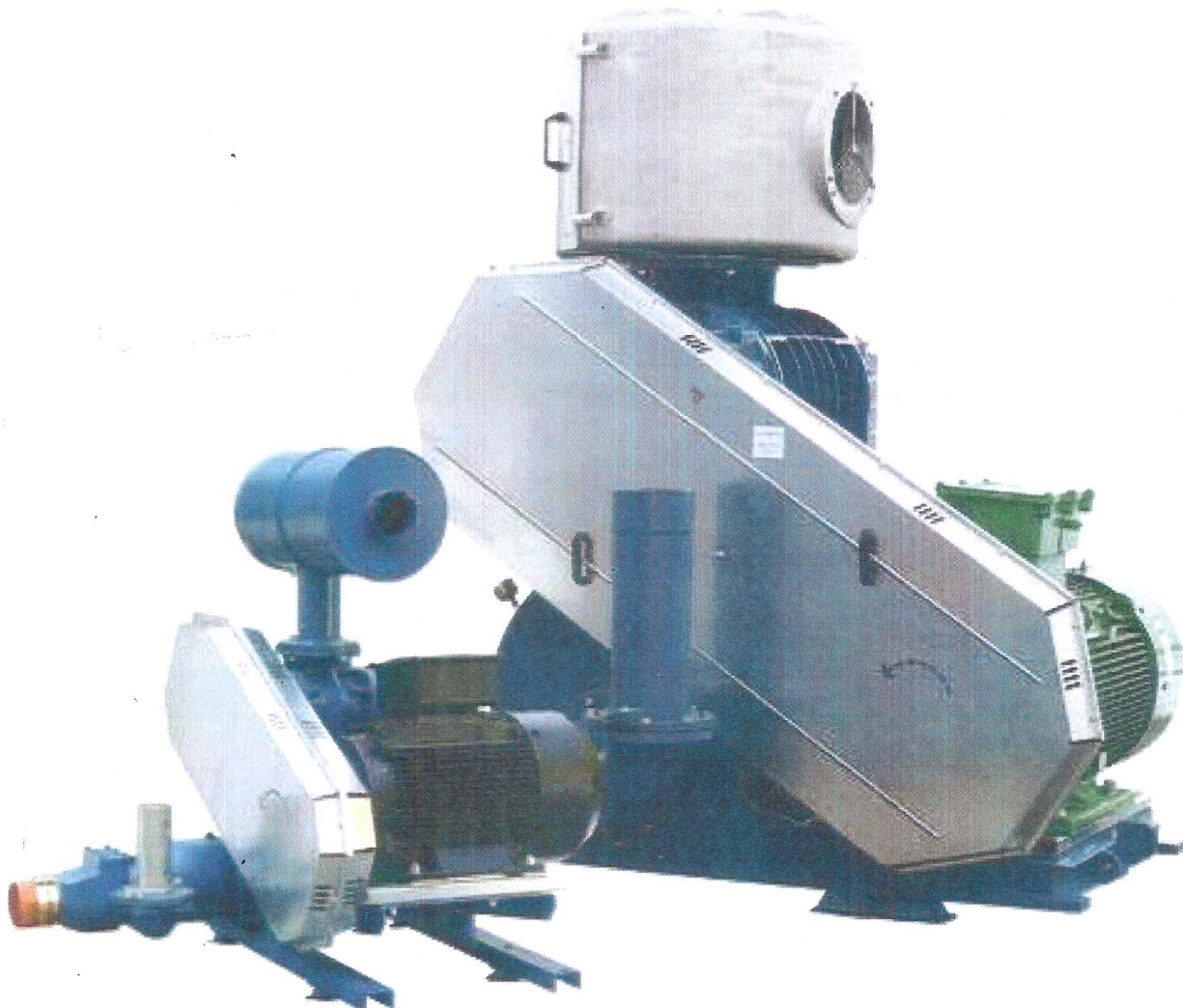

Pulsations eliminated at source

Each of the new Delta Blower units feature a blower stage with internal pulsation cancellation.

Two-Lobe Blowers operating on the Roots principle produce conveying pulsations due to their design, which can be detrimental not only to the blower itself but also to the conveying pipework.

Using a patented development by Aerzener Maschinenfabrik, these pulsations are almost eliminated at source. To achieve this the three-lobe blower has two channels cast into the cylinder wall that control the backstream of gas into the cylinder. This backstream produces sound waves which by interference cancel most of those produced by the blower.

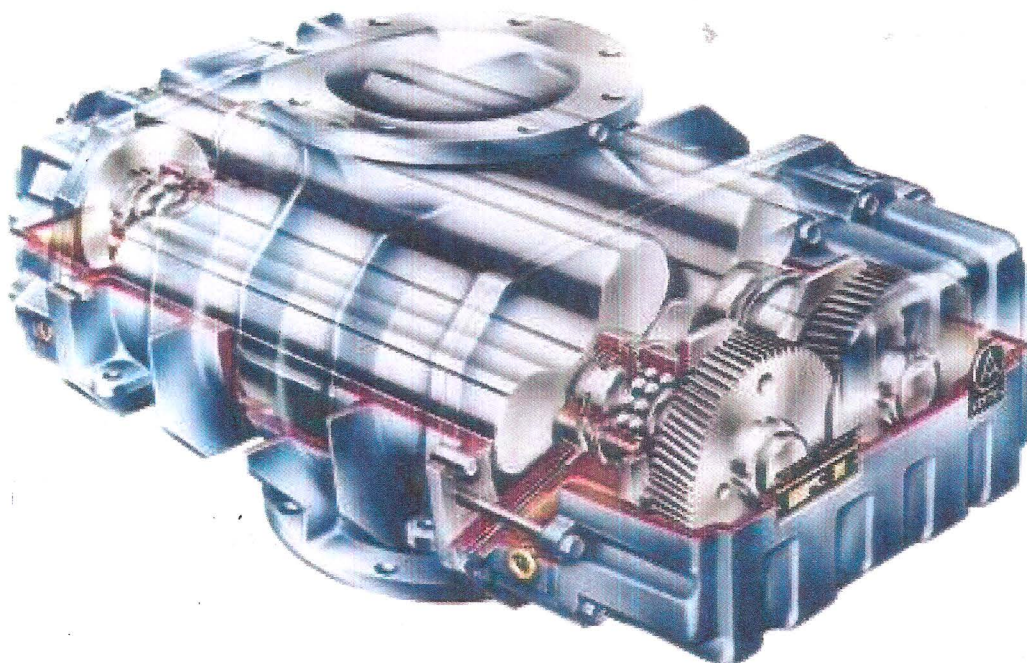
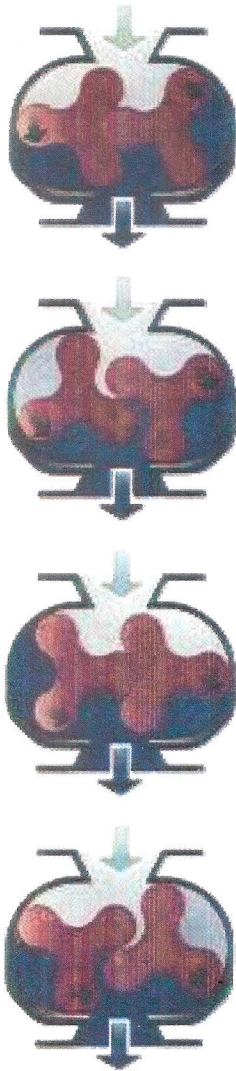

Fields of application

The Delta Blower unit has been designed for the conveying of air and neutral gases.

The flexible modular design makes it possible to combine the accessories of one nominal flange size with corresponding blowers and motor sizes. With all the possible motor sizes and corresponding V-belt drives that can be fitted to one basic frame it is possible to match the present requirements very closely but still leave scope for future operating changes.

The blowers are available in 16 sizes for intake volumes from 30 m³/hour up to 15.000 m³/hour and discharge pressures up to 1000 mbar depending on the blower size. Higher intake volume flows on request.

Fields of application for standard design:

Water Treatment Basin Aeration, Filter Flushing

Pneumatics: Pneumatic conveying of bulk materials for example foodstuffs, granulated plastic material, cement and many other materials

Other areas of the process industry and environmental protection.

Experience in the manufacture of twin-shaft machines is backed by a Quality Control System according to DIN ISO 9001 of which Aerzener has been a certified member since 1990.

Design and fabrication of the machines are carried out in accordance with the following harmonized standards:

- EMV-directive 89/336/EC
- pressure equipment directive 97/23/EC
- low-voltage directive 73/23/EC
- EC-machine directive 98/37/EC

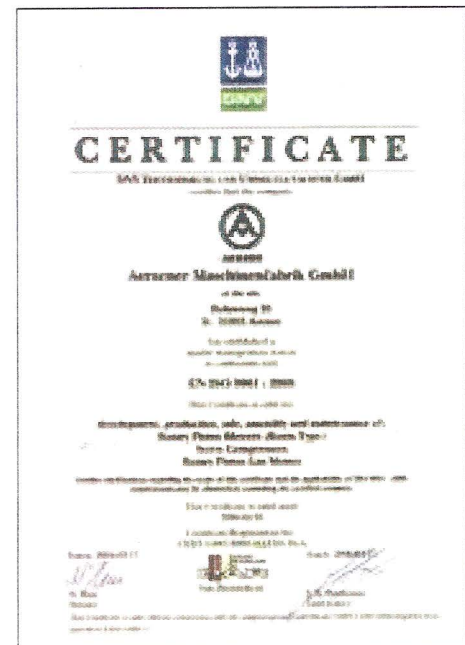

Construction and Manufacture

Blower

The blower has three-lobe rotors and the cylinder housing has pre-inlet channels to reduce sound emissions through pulsation cancellation.

The cylinder, end plates and covers are made of EN-GJL-200.

Rotors

Three-lobe rotors, sizes GM 3 S to GM 80 L are in one-piece-drop-forged steel of C 45 N. GM 90 S and GM 130 L rotors and shafts in one piece of EN-GJS-500-7. GM 150 S to GM 240 S out of EN-GJS-400-18-LT, shafts out of C 45 N.

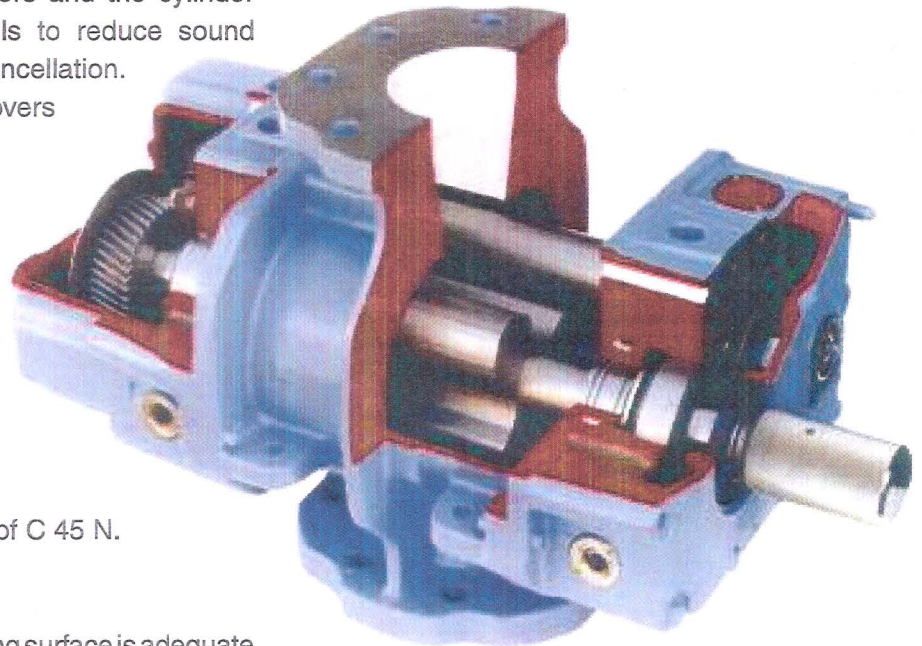

Cooling

Convection cooling via the housing surface is adequate for blowers operating within their thermal range as shown in the performance tables.

Lubrication

Bearings and timing gears are splash lubricated.

Oilfree conveying (Sealing)

The conveying chamber (cylinder) is sealed from the gear case and the front cover by piston ring labyrinth seals. These seals have a central, neutral chamber which is open to the atmosphere.

Timing Gears

The helical timing gears are hardened and ground. They are fitted to the shafts by the oil expanded taper method.

The Blower Unit

By using a three-lobe blower in combination with the pre-inlet a pulsation decrease can be obtained and a completely new concept in package design is possible.

The ancillary items used to make up the complete unit are all mounted on the discharge silencer / base assembly.

This assembly contains no absorption material and is wear-resistant, it has been designed to produce

constant noise reduction over the total speed range of the blower fitted to it. This silencer corresponds to pressure equipment directive PED 97/23/EC. Additional silencers are not required under normal use.

Experience over many years with the use of V-belt drives has led us to develop them further. The drive motor is mounted on a hinged motor plate, this configuration means that the belt drive is always at its optimum tension and is retained automatically by the weight of the motor.

Each unit is delivered with all the standard items needed to operate the unit. Anti-vibration mountings are supplied as a standard, therefore, no special foundations are required.

Modified DELTA BLOWER-units for the North-American market (with NEMA-motors) can be supplied up to nominal width DN 200.

Prompt ability of application

Connect conveying pipings, fill up lube oil, effect electrical connection and the blower is ready for operation. The mounting costs are kept to a minimum with this installation.

Description of individual components

The Blower Stage (1)

Vertical conveying from top to bottom, rotation anti-clockwise looking at the drive shaft.

Base Frame / Discharge Silencer (2)

Is a distortion-free chamber made of steel.

The Intake System (3)

Is constructed as a combination of intake silencer and air intake filter. The parts are contained in a combined housing which is directly mounted to the blower intake flange. The weather-proof housing is designed to allow the filter element to be easily changed.

Standard design: Suction from the atmosphere (mass-produced). Suction via suction piping: Possible against extra costs

The Drive (4)

The blower is driven by a three-phase motor via a heavy-duty narrow V-belt drive. (5)

The Connection Housing (6)

in a cast design (DN 50 up to DN 200) or in welded design (DN 250 up to DN 400), each with vertically mounted pressure valve acc. to PED 97/23/EC (7) as well as installed non-return flap (8).

Accessories (extra price)

- driving motor, type of construction B3, junction box on top, suitable for belt drive, cable entry from fan side
- acoustic hood, forced ventilated by means of fan wheel on blower shaft for indoor- or outdoor installation with oil collecting sump (DN 50 up to DN 300). In case of order please advise place of installation!
- acoustic hood, forced ventilation for indoor- or outdoor installation without oil collecting sump (DN 400). In case of order please advise place of installation!
- discharge side expansion joint instead of flexible connection (9)
- start-up unloading device: required for star-delta starting of the motor
- pressure gauge for indication of the feed pressure
- maintenance indicator for monitoring of the intake filter
- switch cabinet

Further accessories on request !

Technical details can be obtained from the parent company, the technical Sales offices, agencies and representations.

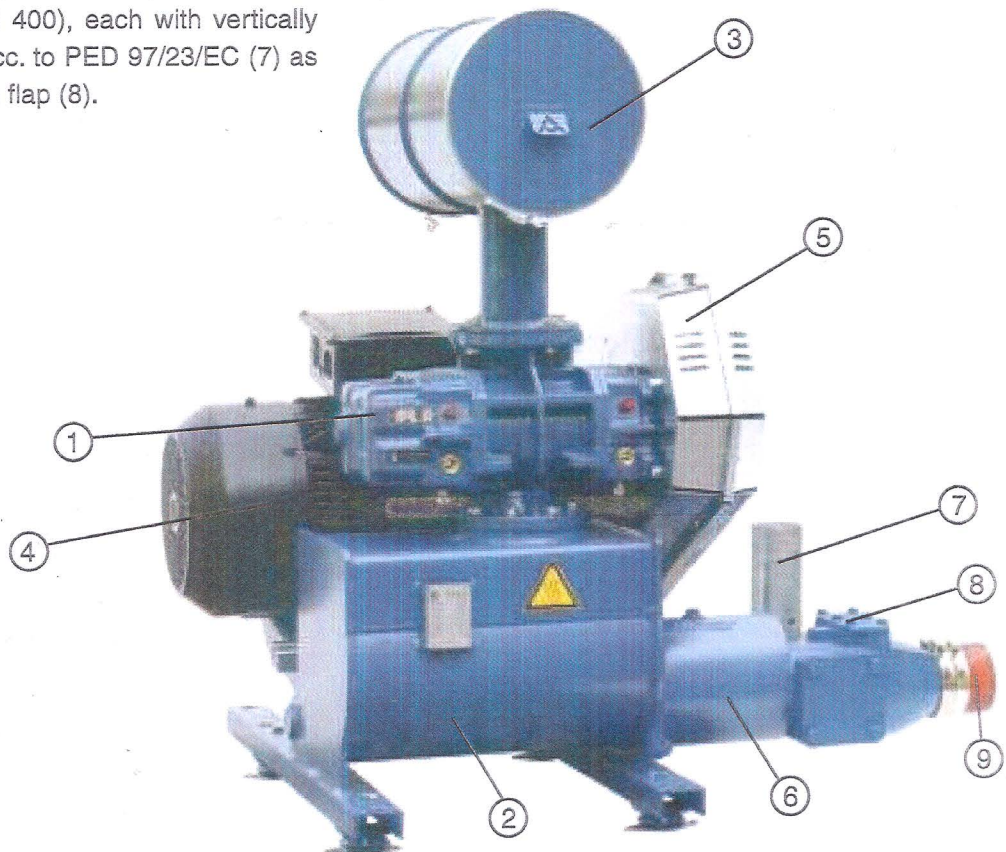

Noise rating

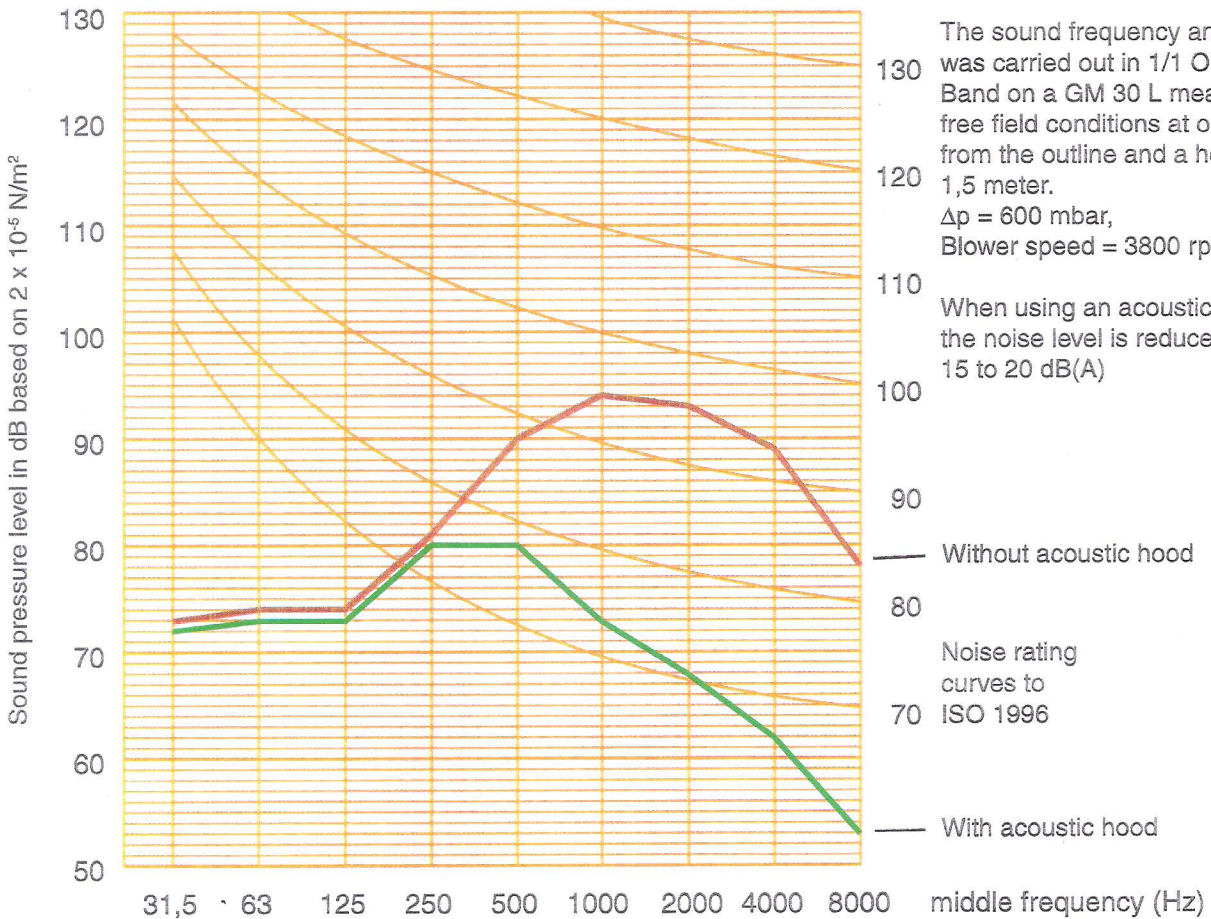

Using the operating data sheets

Please refer to the data sheets for intake volume (\dot{V}_1), absorbed power (P_k), motor size and sound pressure levels $L_p(A)$.

The intake volumes shown correspond to operating speed increments of approximately 12% and are based on commonly available belt drive ratios.

Lower driving speeds are possible, depending on the final temperature.

Max. final temperature: t_2 max. = 140 °C.

The limit temperature is also applicable at increased intake temperature t_1 up to max. 60 °C, provided that the ambient temperature corresponds to intake temperature.

Concerning data please refer to performance diagram.

Data Legend

\dot{V}_1	[m ³ /min]	intake volume
p_1	[bar abs]	intake pressure
Δp	[mbar]	differential pressure
t_1	[°C]	intake temperature
t_2	[°C]	final temperature
nG	[rpm]	blower speed
nM	[rpm]	motor speed
P_k	[kW]	power at blower shaft
P_{mot}	[kW]	motor power rating
$L_p(A)$ w/o.H.	[dB]	sound pressure level for blower unit without hood
$L_p(A)$ w.H.	[dB]	sound pressure level for blower unit with hood

Noise level guarantee

All noise data are based upon machine emitted noise pressure level $L_p(A)$ from each single blower unit. They refer to free field measurements (Tolerance ± 2 dB) as per DIN 45635 at a distance of 1 m.

Performance data for air (p₁ = 1,0 bar, t₁ = 20 °C, ρ = 1,189 kg/m³) overpressure

Δp [mbar]	Blower size	GM 3 S / DN 50										GM 4 S / DN 80								
300	V ₁ [m ³ /min]	0,66	1,10	1,61	2,13	2,48	2,94	3,18	3,66	3,87	4,12	1,01	1,66	2,17	3,00	3,54	4,16	4,78	5,41	5,70
	t ₂ [°C]	74	62	57	54	53	52	51	50	50	50	68	59	56	53	52	51	50	49	49
	nG [rpm]	1400	1830	2330	2840	3190	3640	3880	4350	4560	4800	1400	1870	2240	2840	3230	3680	4130	4590	4800
	nM [rpm]	2800	2800	2800	2840	2840	2840	2870	2870	2870	2890	2800	2800	2840	2840	2870	2870	2890	2890	2890
	P _k [kW]	0,89	1,14	1,43	1,76	2,01	2,34	2,54	2,94	3,13	3,37	1,14	1,49	1,78	2,29	2,64	3,06	3,52	4,01	4,25
	P _{mot} [kW]	1,5	1,5	2,2	3	3	3	4	4	4	5,5	1,5	2,2	3	3	4	4	5,5	5,5	5,5
	Motor size	90 S	90 S	90 L	100 L	100 L	100 L	112 M	112 M	112 M	132 S	90 S	90 L	100 L	100 L	112 M	112 M	132 S	132 S	132 S
	Lp(A)[dB]w _o .H./w.H.	78/68	80/70	83/71	87/72	87/73	89/75	90/74	92/75	93/76	93/76	77/65	78/65	79/66	79/66	84/66	86/69	87/69	88/70	89/71
	400	V ₁ [m ³ /min]	0,55	0,98	1,53	2,01	2,4	2,86	3,07	3,57	3,79	4,00	0,87	1,50	2,21	2,90	3,42	4,06	4,64	5,27
t ₂ [°C]		107	83	73	68	66	64	63	62	61	61	94	77	70	66	64	62	61	60	60
nG [rpm]		1400	1830	2370	2840	3220	3680	3880	4380	4590	4800	1400	1860	2370	2870	3250	3710	4130	4590	4800
nM [rpm]		2800	2800	2840	2840	2870	2870	2870	2890	2890	2890	2800	2840	2840	2870	2890	2890	2890	2890	2890
P _k [kW]		1,13	1,45	1,86	2,24	2,57	3	3,19	3,71	3,94	4,18	1,46	1,91	2,43	2,97	3,4	3,94	4,47	5,07	5,35
P _{mot} [kW]		1,5	2,2	3	3	4	4	4	5,5	5,5	5,5	2,2	3	3	4	5,5	5,5	5,5	7,5	7,5
Motor size		90 S	90 L	100 L	100 L	112 M	112 M	112 M	132 S	132 S	132 S	90 L	100 L	100 L	112 M	132 S	132 S	132 S	132 S	132 S
Lp(A)[dB]w _o .H./w.H.		80/69	81/71	84/72	87/73	87/74	90/75	91/75	93/75	94/76	94/76	77/65	79/67	81/67	83/68	85/67	87/70	88/71	89/72	89/72
500		V ₁ [m ³ /min]	0,91	1,43	1,94	2,29	2,78	3,04	3,47	3,68	3,90	0,77	1,42	2,11	2,80	3,30	3,93	4,51	5,14	5,43
	t ₂ [°C]	107	91	83	80	77	75	74	73	72	126	97	85	80	77	75	73	72	71	
	nG [rpm]	1860	2370	2870	3220	3700	3960	4380	4590	4800	1420	1890	2390	2890	3250	3710	4130	4590	4800	
	nM [rpm]	2840	2840	2870	2870	2890	2890	2890	2890	2890	2840	2840	2870	2890	2890	2890	2890	2890	2890	
	P _k [kW]	1,78	2,26	2,76	3,12	3,64	3,94	4,45	4,72	4,99	1,81	2,38	3,00	3,66	4,15	4,8	5,42	6,12	6,45	
	P _{mot} [kW]	3	3	4	4	5,5	5,5	5,5	7,5	7,5	3	3	4	5,5	5,5	7,5	7,5	7,5	7,5	
	Motor size	100 L	100 L	112 M	112 M	132 S	132 S	132 S	132 S	132 S	100 L	100 L	112 M	132 S	132 S	132 S	132 S	132 S	132 S	
	Lp(A)[dB]w _o .H./w.H.	83/72	85/72	88/73	88/74	91/76	93/76	95/76	95/76	95/76	77/65	80/68	82/68	85/69	86/68	88/71	90/73	89/73	89/73	
	600	V ₁ [m ³ /min]	1,36	1,84	2,26	2,69	2,95	3,38	3,59	3,80	1,33	2,02	2,69	3,39	3,82	4,40	5,11	5,32		
t ₂ [°C]		110	99	94	90	88	86	85	84	119	103	95	90	87	85	83	83			
nG [rpm]		2390	2870	3280	3700	3960	4380	4590	4800	1910	2410	2890	3400	3710	4130	4650	4800			
nM [rpm]		2870	2870	2890	2890	2890	2890	2890	2890	2870	2890	2890	2890	2890	2890	2930	2930			
P _k [kW]		2,69	3,24	3,74	4,27	4,61	5,19	5,49	5,8	2,84	3,58	4,32	5,14	5,65	6,37	7,29	7,56			
P _{mot} [kW]		4	4	5,5	5,5	7,5	7,5	7,5	7,5	4	5,5	5,5	7,5	7,5	7,5	11	11			
Motor size		112 M	112 M	132 S	132 S	132 S	132 S	132 S	132 S	112 M	132 S	132 S	132 S	132 S	132 S	160 M	160 M			
Lp(A)[dB]w _o .H./w.H.		87/73	89/74	89/75	92/76	95/76	96/76	96/76	96/76	81/69	84/70	87/70	87/69	88/72	91/75	89/74	89/74			
700		V ₁ [m ³ /min]	1,27	1,78	2,17	2,60	2,86	3,29	3,50	3,72	1,92	2,58	3,28	3,71	4,37	5,01	5,22			
	t ₂ [°C]	132	117	110	105	102	99	98	97	122	111	104	101	97	95	94				
	nG [rpm]	2390	2890	3280	3700	3960	4380	4590	4800	2410	2890	3400	3710	4190	4650	4800				
	nM [rpm]	2870	2890	2890	2890	2890	2890	2890	2890	2890	2890	2890	2890	2930	2930	2930				
	P _k [kW]	3,09	3,76	4,29	4,9	5,28	5,93	6,27	6,62	4,14	4,99	5,92	6,5	7,43	8,35	8,66				
	P _{mot} [kW]	4	5,5	5,5	7,5	7,5	7,5	7,5	7,5	5,5	7,5	7,5	7,5	11	11	11				
	Motor size	112 M	132 S	132 S	132 S	132 S	132 S	132 S	132 S	132 S	132 S	132 S	132 S	160 M	160 M	160 M				
	Lp(A)[dB]w _o .H./w.H.	87/74	90/74	90/75	93/77	94/78	95/78	95/78	96/78	85/71	89/71	86/70	89/73	93/75	90/75	89/75				
	800	V ₁ [m ³ /min]	2,10	2,52	2,78	3,21	2,48	3,26	3,68	4,26	4,91	5,12								
t ₂ [°C]		126	120	117	113	128	118	114	111	107	107									
nG [rpm]		3290	3700	3960	4380	2890	3450	3760	4190	4650	4800									
nM [rpm]		2890	2890	2890	2890	2890	2930	2930	2930	2930	2930									
P _k [kW]		4,86	5,52	5,95	6,68	5,65	6,81	7,46	8,40	9,42	9,77									
P _{mot} [kW]		7,5	7,5	7,5	7,5	7,5	11	11	11	11	11									
Motor size		132 S	132 S	132 S	132 S	132 S	160 M	160 M	160 M	160 M	160 M									
Lp(A)[dB]w _o .H./w.H.		91/76	94/79	93/80	94/79	91/73	87/72	91/74	95/76	91/76	90/76									
900		V ₁ [m ³ /min]	2,71	3,17	3,59	4,19	4,82	5,03												
	t ₂ [°C]	132	133	129	124	120	119													
	nG [rpm]	3960	3450	3760	4190	4650	4800													
	nM [rpm]	2890	2930	2930	2930	2930	2930													
	P _k [kW]	6,63	7,60	8,33	9,36	10,5	10,9													
	P _{mot} [kW]	7,5	11	11	11	15	15													
	Motor size	132 S	160 M	160 M	160 M	160 M	160 M													
	Lp(A)[dB]w _o .H./w.H.	94/79	88/73	92/74	96/77	92/77	92/77													
	1000	V ₁ [m ³ /min]	4,74	4,94																
t ₂ [°C]		133	132																	
nG [rpm]		4650	4800																	
nM [rpm]		2930	2930																	
P _k [kW]		11,6	12																	
P _{mot} [kW]		15	15																	
Motor size		160 M	160 M																	
Lp(A)[dB]w _o .H./w.H.		94/77	94/78																	

Lower differential pressures on request

Performance data for air ($p_1 = 1,0 \text{ bar}$, $t_1 = 20 \text{ }^\circ\text{C}$, $\rho = 1,189 \text{ kg/m}^3$) overpressure

Δp [mbar]	Blower size	GM 7 L / DN 80										GM 10 S / DN 80						GM 10 S / DN 100		
300	\dot{V}_1 [m³/min]	1,54	2,56	3,59	4,63	5,35	6,35	7,19	7,71	8,21	2,59	3,96	5,36	6,70	7,68	9,03	10,3	11,0	11,6	
	t_z [°C]	67	58	55	52	51	50	50	50	49	59	54	52	50	50	49	48	48	48	
	nG [rpm]	1400	1890	2390	2890	3240	3720	4130	4380	4620	1420	1910	2410	2890	3240	3720	4190	4440	4650	
	nM [rpm]	2800	2840	2870	2890	2890	2890	2890	2890	2890	2840	2870	2890	2890	2890	2890	2930	2930	2930	
	Pk [kW]	1,64	2,19	2,78	3,42	3,89	4,59	5,25	5,67	6,10	2,29	3,06	3,88	4,72	5,37	6,36	7,43	8,05	8,61	
	P_{mot} [kW]	2,2	3	4	5,5	5,5	7,5	7,5	7,5	7,5	3	4	5,5	7,5	7,5	7,5	11	11	11	
	Motor size	90 L	100 L	112 M	112 M	132 S	132 S	132 S	132 S	132 S	100 L	112 M	132 S	132 S	132 S	132 S	160 M	160 M	160 M	
	Lp(A)[dB]w/o.H./w.H.	80/<65	82/68	83/68	83/68	85/70	88/71	89/70	89/71	89/71	78/<65	78/<65	80/66	82/68	84/70	86/71	91/74	91/74	92/74	
	400	\dot{V}_1 [m³/min]	1,38	2,39	3,42	4,42	5,14	6,14	7,11	7,63	8,14	2,41	3,80	5,14	6,49	7,58	8,95	10,1	10,8	11,4
t_z [°C]		92	75	69	65	64	62	61	60	60	76	68	64	62	61	59	59	58	58	
nG [rpm]		1420	1910	2410	2890	3240	3720	4190	4440	4690	1435	1930	2410	2890	3280	3770	4190	4440	4650	
nM [rpm]		2840	2870	2890	2890	2890	2890	2930	2930	2930	2870	2890	2890	2890	2930	2930	2930	2930	2930	
Pk [kW]		2,16	2,87	3,64	4,41	5,01	5,88	6,79	7,31	7,85	2,99	3,99	5,00	6,07	6,98	8,23	9,39	10,1	10,8	
P_{mot} [kW]		3	4	5,5	5,5	7,5	7,5	11	11	11	4	5,5	7,5	7,5	11	11	11	15	15	
Motor size		100 L	112 M	132 S	132 S	132 S	132 S	160 M	160 M	160 M	112 M	132 S	132 S	132 S	160 M	160 M	160 M	160 M	160 M	
Lp(A)[dB]w/o.H./w.H.		80/65	82/69	84/69	86/70	86/71	89/72	90/72	90/73	91/73	80/<65	78/65	80/66	83/68	84/70	87/72	91/74	92/74	93/74	
500		\dot{V}_1 [m³/min]	1,22	2,18	3,24	4,23	5,31	6,05	6,92	7,44	7,96	2,25	3,61	4,95	6,41	7,39	8,76	9,94	10,6	11,2
	t_z [°C]	122	95	84	79	76	74	72	72	71	95	83	77	74	72	70	69	69	69	
	nG [rpm]	1435	1900	2410	2890	3410	3770	4190	4440	4690	1445	1930	2410	2930	3280	3770	4190	4440	4650	
	nM [rpm]	2870	2890	2890	2890	2890	2930	2930	2930	2930	2890	2890	2890	2930	2930	2930	2930	2930	2930	
	Pk [kW]	2,67	3,51	4,47	5,41	6,49	7,27	8,24	8,84	9,46	3,68	4,89	6,13	7,52	8,51	9,99	11,3	12,2	12,9	
	P_{mot} [kW]	4	5,5	5,5	7,5	7,5	11	11	11	11	5,5	7,5	7,5	11	11	15	15	15	15	
	Motor size	112 M	132 S	132 S	132 S	132 S	160 M	160 M	160 M	160 M	132 S	132 S	132 S	160 M	160 M	160 M	160 M	160 M	160 M	
	Lp(A)[dB]w/o.H./w.H.	80/67	82/71	84/71	86/71	89/73	90/74	91/74	91/74	92/74	81/<65	78/66	80/67	83/67	84/70	87/73	88/73	92/74	93/74	
	600	\dot{V}_1 [m³/min]	2,08	3,07	4,07	4,87	5,89	6,76	7,27	7,79	2,08	3,44	4,5	6,24	7,22	8,59	9,76	10,5	11,1	
t_z [°C]		116	102	94	90	87	84	83	83	118	99	92	86	84	82	80	80	79		
nG [rpm]		1930	2410	2890	3280	3770	4190	4440	4690	1445	1930	2310	2930	3280	3770	4190	4440	4650		
nM [rpm]		2890	2890	2890	2930	2930	2930	2930	2930	2890	2890	2930	2930	2930	2930	2930	2930	2930		
Pk [kW]		4,24	5,3	6,41	7,34	8,57	9,68	10,4	11,1	4,35	5,8	6,94	8,89	10,0	11,7	13,3	14,3	15,1		
P_{mot} [kW]		5,5	7,5	7,5	11	11	11	15	15	5,5	7,5	11	11	15	15	15	18,5	18,5		
Motor size		132 S	132 S	132 S	160 M	160 M	160 M	160 M	160 M	132 S	132 S	160 M	160 M	160 M	160 M	160 M	160 L	160 L		
Lp(A)[dB]w/o.H./w.H.		84/71	86/72	88/73	89/75	91/76	91/76	92/76	92/76	82/<65	78/67	80/67	84/67	84/70	87/73	88/74	92/74	94/75		
700		\dot{V}_1 [m³/min]	2,92	4,00	4,72	5,71	6,60	7,12	7,64	3,28	4,34	6,08	7,06	8,43	9,61	10,3	10,9			
	t_z [°C]	120	109	104	100	97	96	94	117	107	99	96	93	92	91	91	90			
	nG [rpm]	2410	2930	3280	3760	4190	4440	4690	1930	2310	2930	3280	3770	4190	4440	4650				
	nM [rpm]	2890	2930	2930	2930	2930	2930	2930	2890	2930	2930	2930	2930	2930	2930	2930				
	Pk [kW]	6,13	7,51	8,47	9,84	11,1	11,9	12,7	6,7	8,02	10,3	11,6	13,5	15,3	16,3	17,3				
	P_{mot} [kW]	7,5	11	11	11	15	15	15	7,5	11	15	15	18,5	18,5	18,5	22				
	Motor size	132 S	160 M	160 M	160 M	160 M	160 M	160 M	132 S	160 M	160 M	160 M	160 L	160 L	160 L	160 L				
	Lp(A)[dB]w/o.H./w.H.	88/73	89/75	90/77	92/78	92/78	92/78	92/78	79/68	80/68	84/69	84/72	88/74	89/75	92/74	94/75				
	800	\dot{V}_1 [m³/min]									4,20	5,93	6,91	7,98	9,46	10,2	10,7			
t_z [°C]										123	113	109	106	103	102	101				
nG [rpm]										2310	2930	3280	3660	4190	4440	4650				
nM [rpm]										2930	2930	2930	2930	2930	2930	2930				
Pk [kW]										9,10	11,6	13,1	14,8	17,2	18,4	19,5				
P_{mot} [kW]										11	15	15	18,5	22	22	22				
Motor size										160 M	160 M	160 M	160 L	180 M	180 M	180 M				
Lp(A)[dB]w/o.H./w.H.										81/70	84/71	84/73	87/75	90/77	92/74	93/75				
900		\dot{V}_1 [m³/min]									6,77	7,84	9,32	10,1	10,7					
	t_z [°C]									122	118	115	113	112						
	nG [rpm]									3280	3660	4190	4460	4680						
	nM [rpm]									2930	2930	2930	2945	2945						
	Pk [kW]									14,6	16,5	19,2	20,6	21,8						
	P_{mot} [kW]									18,5	18,5	22	30	30						
	Motor size									160 L	160 L	180 M	200 L	200 L						
	Lp(A)[dB]w/o.H./w.H.									85/72	88/74	89/77	92/74	93/75						
	1000	\dot{V}_1 [m³/min]									7,71	8,72	9,95	10,6						
t_z [°C]										131	128	125	124							
nG [rpm]										3660	4020	4460	4680							
nM [rpm]										2930	2945	2945	2945							
Pk [kW]										18,2	20,2	22,7	24,0							
P_{mot} [kW]										22	30	30	30							
Motor size										180 M	200 L	200 L	200 L							
Lp(A)[dB]w/o.H./w.H.										88/74	89/76	92/74	93/75							

Lower differential pressures on request
 GM 10 S from 10 m³/min - accessories DN 100

Performance data for air ($p_1 = 1,0 \text{ bar}$, $t_1 = 20 \text{ }^\circ\text{C}$, $\rho = 1,189 \text{ kg/m}^3$) overpressure

Δp [mbar]	Blower size	GM 15 L / DN 100										GM 25 S / DN 125							
300	\dot{V}_1 [m³/min]	3,95	5,84	7,99	10,1	11,6	13,6	15,4	16,4	17,3	6,18	8,69	11,1	14,5	16,6	18,7	20,6	22,7	24,2
	t_2 [°C]	58	54	51	50	49	49	48	48	48	53	51	50	48	48	48	47	47	47
	nG [rpm]	1435	1890	2410	2930	3290	3760	4190	4440	4650	1445	1890	2310	2930	3290	3660	4010	4370	4650
	nM [rpm]	2870	2890	2890	2930	2930	2930	2930	2930	2930	2890	2890	2930	2930	2930	2930	2930	2930	2930
	Pk [kW]	3,26	4,34	5,64	7,04	8,07	9,52	10,9	11,8	12,6	4,46	5,86	7,3	9,64	11,1	12,8	14,4	16,2	17,7
	P _{mot} [kW]	4	5,5	7,5	11	11	11	15	15	15	5,5	7,5	11	11	15	15	18,5	18,5	22
	Motor size	112 M	132 S	132 S	160 M	160 M	160 M	160 M	160 M	160 M	132 S	132 S	160 M	160 M	160 M	160 M	160 L	160 L	180 M
	Lp(A)[dB]w.b.H./w.H.	83/69	84/70	85/71	87/72	87/72	89/72	91/73	91/73	91/73	82/<70	85/72	87/72	92/75	92/75	93/76	92/75	94/76	96/76
	400	\dot{V}_1 [m³/min]	3,69	5,53	7,27	9,84	11,3	13,3	15,1	16,1	17,0	5,88	8,56	10,8	14,2	16,3	18,4	20,3	22,5
t_2 [°C]		74	67	64	61	60	59	59	58	58	66	62	60	59	58	58	57	57	57
nG [rpm]		1445	1890	2310	2930	3290	3760	4190	4440	4650	1445	1920	2310	2930	3290	3660	4010	4400	4680
nM [rpm]		2890	2890	2930	2930	2930	2930	2930	2930	2930	2890	2930	2930	2930	2930	2930	2930	2945	2950
Pk [kW]		4,28	5,64	6,97	9,06	10,3	12,1	13,8	14,9	15,8	5,82	7,76	9,47	12,4	14,2	16,2	18,2	20,5	22,2
P _{mot} [kW]		5,5	7,5	11	11	15	15	18,5	18,5	18,5	7,5	11	11	15	18,5	18,5	22	30	30
Motor size		132 S	132 S	160 M	160 M	160 M	160 M	160 L	160 L	160 L	132 S	160 M	160 M	160 M	160 L	160 L	180 M	200 L	200 L
Lp(A)[dB]w.b.H./w.H.		83/70	85/72	86/72	88/72	87/72	88/72	92/75	92/75	93/75	83/<70	86/72	87/72	92/75	93/76	93/77	93/76	95/76	97/77
500		\dot{V}_1 [m³/min]	3,42	5,38	7,00	9,57	11,1	12,6	14,0	15,8	16,7	5,73	8,29	10,5	14,0	16,0	18,1	20,2	22,3
	t_2 [°C]	93	82	77	73	72	70	69	69	68	80	75	72	69	68	68	67	67	66
	nG [rpm]	1445	1920	2310	2930	3290	3660	4010	4440	4650	1465	1920	2310	2930	3290	3660	4030	4400	4680
	nM [rpm]	2890	2930	2930	2930	2930	2930	2930	2930	2930	2930	2930	2930	2930	2930	2930	2945	2945	2950
	Pk [kW]	5,28	7,06	8,57	11,1	12,6	14,3	15,9	18,0	19,0	7,27	9,56	11,6	15,1	17,3	19,6	22,1	24,6	26,6
	P _{mot} [kW]	7,5	11	11	15	15	18,5	18,5	22	22	11	11	15	18,5	22	22	30	30	30
	Motor size	132 S	160 M	160 M	160 M	160 M	160 L	160 L	180 M	180 M	160 M	160 M	160 M	160 L	180 M	180 M	200 L	200 L	200 L
	Lp(A)[dB]w.b.H./w.H.	84/71	87/73	88/72	89/72	88/72	87/73	91/75	94/76	95/76	85/70	88/72	88/72	93/75	93/76	94/78	94/77	97/77	99/78
	600	\dot{V}_1 [m³/min]	3,17	5,14	6,75	9,32	10,8	12,3	14,5	15,7	16,6	5,49	8,05	10,2	13,7	15,9	18,0	19,9	22,0
t_2 [°C]		115	98	91	85	83	82	80	79	79	95	87	84	80	79	78	77	77	76
nG [rpm]		1445	1920	2310	2930	3290	3660	4190	4460	4680	1465	1920	2310	2930	3310	3680	4030	4400	4680
nM [rpm]		2890	2930	2930	2930	2930	2930	2930	2945	2945	2930	2930	2930	2930	2945	2945	2945	2950	2950
Pk [kW]		6,28	8,38	10,2	13,1	14,9	16,8	19,6	21,1	22,4	8,65	11,4	13,8	17,9	20,5	23,2	25,8	28,7	31,0
P _{mot} [kW]		7,5	11	15	15	18,5	22	22	30	30	11	15	18,5	22	30	30	30	37	37
Motor size		132 S	160 M	160 M	160 M	160 L	180 M	180 M	200 L	200 L	160 M	160 M	160 L	180 M	200 L	200 L	200 L	200 L	200 L
Lp(A)[dB]w.b.H./w.H.		86/72	88/73	88/73	89/73	88/73	88/73	92/76	94/77	97/78	86/72	89/73	89/72	93/75	94/77	95/78	96/78	98/78	100/79
700		\dot{V}_1 [m³/min]		4,91	6,53	9,10	10,6	12,1	13,6	15,4	16,3	5,27	7,83	10,0	13,6	15,7	17,7	20,1	21,8
	t_2 [°C]		115	106	98	95	93	92	90	89	112	101	96	91	90	88	87	87	86
	nG [rpm]		1920	2310	2930	3290	3660	4030	4460	4680	1465	1920	2310	2945	3310	3680	4100	4400	4670
	nM [rpm]		2930	2930	2930	2930	2930	2945	2945	2945	2930	2930	2930	2945	2945	2945	2950	2950	2940
	Pk [kW]		9,71	11,8	15,1	17,2	19,3	21,5	24,2	25,6	10,0	13,2	16,0	20,8	23,6	26,7	30,2	32,9	35,3
	P _{mot} [kW]		11	15	18,5	22	22	30	30	30	15	15	18,5	30	30	30	37	37	45
	Motor size		160 M	160 M	160 L	180 M	180 M	200 L	200 L	200 L	160 M	160 M	160 L	200 L	200 L	200 L	200 L	200 L	225 M
	Lp(A)[dB]w.b.H./w.H.		88/74	88/74	89/73	89/73	89/73	90/75	95/77	98/80	87/72	90/74	91/73	93/76	94/77	96/79	97/79	98/79	100/80
	800	\dot{V}_1 [m³/min]										5,06	7,68	9,8	13,4	15,4	17,6	19,8	21,5
t_2 [°C]											129	115	109	103	101	99	98	97	96
nG [rpm]											1465	1930	2310	2945	3310	3690	4080	4390	4670
nM [rpm]											2930	2930	2930	2945	2945	2950	2940	2940	2940
Pk [kW]											11,4	15	18,1	23,5	26,7	30,2	33,9	36,9	39,7
P _{mot} [kW]											15	18,5	22	30	30	37	45	45	45
Motor size											160 M	160 L	180 M	200 L	200 L	200 L	225 M	225 M	225 M
Lp(A)[dB]w.b.H./w.H.											88/72	91/75	92/74	94/76	95/78	96/79	97/79	99/80	101/82
900		\dot{V}_1 [m³/min]										7,49	9,68	13,2	15,3	17,3	19,6	21,4	23,0
	t_2 [°C]										129	122	115	112	110	108	107	106	
	nG [rpm]										1930	2320	2945	3320	3680	4080	4410	4690	
	nM [rpm]										2930	2945	2945	2950	2950	2940	2960	2960	
	Pk [kW]										16,9	20,4	26,3	30,0	33,6	37,7	41,2	44,3	
	P _{mot} [kW]										22	30	30	37	37	45	55	55	
	Motor size										180 M	200 L	200 L	200 L	200 L	225 M	250 M	250 M	
	Lp(A)[dB]w.b.H./w.H.										92/77	94/77	95/78	96/79	97/80	97/81	99/81	101/82	
	1000	\dot{V}_1 [m³/min]													13,0	15,1	17,2	19,5	21,3
t_2 [°C]														127	123	121	119	118	117
nG [rpm]														2950	3320	3680	4100	4410	4690
nM [rpm]														2950	2950	2940	2960	2960	2960
Pk [kW]														29,1	33,1	37,0	41,8	45,4	48,7
P _{mot} [kW]														37	37	45	55	55	55
Motor size														200 L	200 L	225 M	250 M	250 M	250 M
Lp(A)[dB]w.b.H./w.H.														97/80	97/81	98/82	98/82	100/82	102/83

Lower differential pressures on request

Performance data for air ($p_1 = 1,0 \text{ bar}$, $t_1 = 20 \text{ }^\circ\text{C}$, $\rho = 1,189 \text{ kg/m}^3$) overpressure

Ap [mbar]	Blower size	GM 30 L / DN 150										GM 35 S / DN 150							
300	\dot{V}_1 [m³/min]	8,68	11,7	15,6	20,5	23,3	26,3	29,2	32,7	34,7	14,0	18,2	23,6	27,1	30,6	34,6	38,8	40,3	
	t_2 [°C]	53	51	50	49	48	48	48	47	47	50	49	48	48	47	47	47	47	
	nG [rpm]	1445	1830	2310	2930	3280	3660	4020	4460	4710	1490	1860	2330	2640	2945	3300	3670	3800	
	nM [rpm]	2890	2930	2930	2930	2930	2930	2945	2945	2945	2930	2930	2930	2930	2945	2945	2950	2950	
	Pk [kW]	6,38	8,13	10,5	13,7	15,7	17,9	20,2	23,1	24,8	9,56	12,2	15,8	18,4	21,2	24,9	29,1	30,7	
	P_{mot} [kW]	7,5	11	15	18,5	18,5	22	30	30	30	11	15	18,5	22	30	30	37	37	
	Motor size	132 S	160 M	160 M	160 M	160 L	180 M	200 L	200 L	200 L	160 M	160 M	160 L	180 M	200 L	200 L	200 L	200 L	
	Lp(A)[dB]w/o.H./w.H.	84/71	86/<70	88/71	88/71	93/76	95/77	96/77	97/78	97/79	86/70	90/74	92/76	91/76	91/77	92/79	96/81	99/81	
	400	\dot{V}_1 [m³/min]	8,41	12,0	15,1	20,1	23,0	26,0	28,7	32,3	34,3	13,6	17,8	23,2	26,4	30,1	34,2	38,2	39,8
t_2 [°C]		66	63	61	59	58	58	57	57	57	62	60	58	58	57	57	56	56	
nG [rpm]		1465	1920	2310	2930	3300	3680	4020	4470	4720	1490	1860	2340	2620	2945	3300	3660	3800	
nM [rpm]		2930	2930	2930	2930	2945	2945	2945	2950	2950	2930	2930	2945	2945	2945	2950	2940	2940	
Pk [kW]		8,41	11,1	13,5	17,6	20,2	22,9	25,5	29,1	31,2	12,4	15,7	20,3	23,2	26,8	31,1	35,9	37,9	
P_{mot} [kW]		11	15	18,5	22	30	30	30	37	37	15	18,5	30	30	30	37	45	45	
Motor size		160 M	160 M	160 L	180 M	200 L	200 L	200 L	200 L	200 L	160 M	160 L	200 L	200 L	200 L	200 L	225 M	225 M	
Lp(A)[dB]w/o.H./w.H.		85/71	88/70	89/71	91/75	93/76	95/78	96/77	98/78	99/79	87/70	90/75	93/77	92/77	92/78	94/80	97/81	99/81	
500		\dot{V}_1 [m³/min]	8,02	11,7	14,7	19,8	22,6	25,7	28,4	31,3	33,8	12,9	17,4	22,9	26,0	29,8	33,6	38,1	39,4
	t_2 [°C]	81	75	72	70	69	68	67	67	66	74	71	69	68	67	66	66	66	
	nG [rpm]	1465	1930	2310	2945	3300	3690	4020	4390	4700	1465	1860	2340	2620	2950	3290	3680	3800	
	nM [rpm]	2930	2930	2930	2945	2945	2950	2950	2940	2940	2930	2930	2945	2950	2950	2940	2955	2955	
	Pk [kW]	10,4	13,7	16,6	21,6	24,6	27,9	30,9	34,3	37,2	14,9	19,2	24,7	28,2	32,5	37,2	43,2	45,1	
	P_{mot} [kW]	15	18,5	22	30	30	37	37	45	45	18,5	22	30	37	37	45	55	55	
	Motor size	160 M	160 L	180 M	200 L	200 L	200 L	200 L	225 M	225 M	160 L	180 M	200 L	200 L	200 L	225 M	250 M	250 M	
	Lp(A)[dB]w/o.H./w.H.	86/72	90/70	90/72	91/75	93/76	95/78	97/78	99/78	100/80	87/71	91/75	94/77	93/77	93/79	96/80	98/81	100/82	
	600	\dot{V}_1 [m³/min]	7,68	10,6	14,6	19,5	22,3	25,4	28,5	31,0	33,7	12,6	16,8	22,5	25,7	29,3	33,5	37,9	39,1
t_2 [°C]		96	89	84	81	79	78	77	77	76	87	82	79	78	77	76	76	75	
nG [rpm]		1465	1830	2330	2945	3300	3690	4080	4390	4730	1465	1840	2340	2620	2940	3310	3700	3800	
nM [rpm]		2930	2930	2950	2945	2950	2950	2940	2940	2960	2930	2945	2950	2950	2940	2955	2970	2970	
Pk [kW]		12,3	15,4	19,8	25,5	28,9	32,8	36,8	40,1	43,8	17,7	22,5	29,2	33,1	37,9	43,8	50,5	52,3	
P_{mot} [kW]		15	18,5	30	30	37	37	45	45	55	22	30	37	37	45	55	75	75	
Motor size		160 M	160 L	200 L	200 L	200 L	200 L	225 M	225 M	250 M	180 M	200 L	200 L	200 L	225 M	250 M	280 S	280 S	
Lp(A)[dB]w/o.H./w.H.		86/73	89/72	90/73	92/75	94/77	97/79	99/80	99/80	100/81	87/72	91/76	95/78	94/78	93/79	99/81	99/82	100/82	
700		\dot{V}_1 [m³/min]	7,36	10,3	14,2	19,2	22,0	24,8	28,3	30,8	33,6	12,3	16,5	22,2	25,7	29,2	33,4	37,6	38,8
	t_2 [°C]	113	103	96	92	90	89	87	87	86	100	94	90	89	87	86	85	85	
	nG [rpm]	1465	1830	2330	2950	3300	3660	4100	4410	4760	1475	1840	2340	2650	2955	3330	3700	3800	
	nM [rpm]	2930	2930	2945	2950	2950	2940	2955	2960	2970	2945	2945	2950	2940	2955	2970	2970	2970	
	Pk [kW]	14,2	17,8	22,9	29,5	33,3	37,4	42,5	46,2	50,5	20,6	26,0	33,6	38,6	43,7	50,4	57,5	59,5	
	P_{mot} [kW]	18,5	22	30	37	37	45	55	55	75	30	30	37	45	55	75	75	75	
	Motor size	160 L	180 M	200 L	200 L	200 L	225 M	250 M	250 M	280 S	200 L	200 L	200 L	225 M	250 M	280 S	280 S	280 S	
	Lp(A)[dB]w/o.H./w.H.	86/73	89/74	90/74	94/75	96/77	100/81	102/82	99/81	99/82	88/72	91/76	94/78	95/78	96/80	100/82	100/82	101/82	
	800	\dot{V}_1 [m³/min]										12,0	16,2	21,7	25,5	28,8	33,1	35,3	38,4
t_2 [°C]											113	106	101	99	98	97	96	95	
nG [rpm]											1475	1840	2330	2660	2955	3330	3520	3800	
nM [rpm]											2945	2950	2940	2960	2955	2970	2970	2970	
Pk [kW]											23,4	29,4	37,8	43,8	49,3	56,7	60,7	66,7	
P_{mot} [kW]											30	37	45	55	55	75	75	75	
Motor size											200 L	200 L	225 M	250 M	250 M	280 S	280 S	280 S	
Lp(A)[dB]w/o.H./w.H.											89/73	92/77	94/79	96/79	98/81	101/82	101/82	102/83	
900		\dot{V}_1 [m³/min]										11,8	15,9	21,7	24,9	28,7	32,8	37,0	38,2
	t_2 [°C]										127	119	113	110	108	107	106	105	
	nG [rpm]										1475	1840	2350	2630	2970	3330	3700	3800	
	nM [rpm]										2945	2950	2955	2955	2970	2970	2970	2970	
	Pk [kW]										26,2	32,9	42,6	48,2	55,2	63,0	71,5	73,9	
	P_{mot} [kW]										30	37	55	55	75	75	90	90	
	Motor size										200 L	200 L	250 M	250 M	280 S	280 S	280 M2	280 M2	
	Lp(A)[dB]w/o.H./w.H.										89/73	92/78	95/79	96/80	99/81	101/83	102/83	103/84	
	1000	\dot{V}_1 [m³/min]										15,6	21,4	24,7	28,5	30,3	36,8	37,9	
t_2 [°C]											132	124	122	119	118	116	115		
nG [rpm]											1840	2350	2640	2970	3130	3700	3800		
nM [rpm]											2940	2955	2970	2970	2970	2970	2970		
Pk [kW]											36,4	47,1	53,4	60,9	64,6	78,5	81,1		
P_{mot} [kW]											45	55	75	75	75	90	90		
Motor size											225 M	250 M	280 S	280 S	280 S	280 M2	280 M2		
Lp(A)[dB]w/o.H./w.H.											92/78	95/80	97/80	100/82	101/83	102/84	104/85		

Lower differential pressures on request

Performance data for air (p₁ = 1,0 bar, t₁ = 20 °C, ρ = 1,189 kg/m³) overpressure

Δp [mbar]	Blower size	GM 50 L / DN 150							GM 50 L / DN 200			GM 60 S / DN 200								
300	V ₁ [m ³ /min]	19,7	22,5	26,0	33,7	38,2	41,1	43,5	49,1	52,2	55,1	20,1	26,9	30,9	35,7	40,1	45,9	52,4	55,7	59,0
	t ₂ [°C]	50	49	49	48	48	47	47	47	47	47	51	50	49	49	48	48	47	47	47
	nG [rpm]	1465	1640	1860	2340	2620	2800	2950	3300	3490	3670	1150	1465	1650	1870	2070	2340	2640	2790	2940
	nM [rpm]	2930	2930	2930	2945	2945	2950	2950	2950	2940	2940	2930	2930	2945	2945	2945	2950	2940	2940	2940
	P _k [kW]	13,2	15,0	17,5	23,4	27,2	29,8	32,1	32,8	35,4	38,0	13,4	17,4	19,9	23,0	26,0	30,1	34,9	37,4	40,0
	P _{mot} [kW]	15	18,5	22	30	30	37	37	37	45	45	15	22	30	30	30	37	45	45	45
	Motor size	160 M	160 L	180 M	200 L	200 L	200 L	200 L	200 L	225 M	225 M	160 M	180 M	200 L	200 L	200 L	200 L	225 M	225 M	225 M
	Lp(A)[dB]w _b .H.w.H.	86/73	88/74	90/75	92/79	91/77	92/78	92/79	98/81	98/82	100/82	85/71	88/73	91/75	96/79	96/79	97/79	98/80	98/81	99/81
	400	V ₁ [m ³ /min]	19,1	21,9	25,1	33,2	38,1	40,4	42,8	48,7	51,4	54,8	19,3	26,4	30,2	35,0	39,7	45,0	52,1	55,2
t ₂ [°C]		61	60	59	58	57	57	57	56	56	56	63	61	60	59	58	58	57	57	57
nG [rpm]		1465	1640	1840	2340	2650	2790	2940	3310	3480	3690	1150	1475	1650	1870	2090	2330	2660	2800	2970
nM [rpm]		2930	2930	2945	2950	2940	2940	2940	2955	2955	2960	2930	2945	2945	2950	2940	2940	2955	2955	2970
P _k [kW]		17,1	19,4	22,2	29,6	34,7	37,2	39,8	41,8	44,6	48,1	17,5	22,9	25,9	29,8	33,9	38,4	44,9	47,7	51,2
P _{mot} [kW]		22	22	30	37	45	45	45	55	55	55	22	30	30	37	45	45	55	55	75
Motor size		180 M	180 M	200 L	200 L	225 M	225 M	225 M	250 M	250 M	250 M	180 M	200 L	200 L	200 L	225 M	225 M	250 M	250 M	280 S
Lp(A)[dB]w _b .H.w.H.		87/73	88/74	91/75	92/79	92/79	92/79	92/80	98/82	99/82	100/82	87/72	89/74	92/77	96/80	97/79	97/79	99/80	99/81	100/82
500		V ₁ [m ³ /min]	18,8	21,6	24,6	32,5	37,8	40,0	42,5	48,4	51,2	54,6	18,9	25,7	29,5	34,3	39,3	44,5	51,5	54,9
	t ₂ [°C]	73	71	70	68	67	67	67	66	66	66	76	72	71	70	69	68	67	67	66
	nG [rpm]	1475	1650	1840	2330	2660	2800	2955	3320	3500	3710	1160	1475	1650	1870	2100	2340	2660	2820	2970
	nM [rpm]	2945	2945	2945	2940	2955	2955	2955	2970	2970	2970	2945	2950	2950	2940	2955	2955	2970	2970	2970
	P _k [kW]	21,2	24,0	27,1	35,7	42,0	44,8	48,0	50,9	54,3	58,4	21,9	28,2	31,9	36,6	41,6	47,1	54,5	58,3	62,0
	P _{mot} [kW]	30	30	30	45	55	55	55	75	75	75	30	37	37	45	55	55	75	75	75
	Motor size	200 L	200 L	200 L	225 M	250 M	250 M	250 M	280 S	280 S	280 S	200 L	200 L	200 L	225 M	250 M	250 M	280 S	280 S	280 S
	Lp(A)[dB]w _b .H.w.H.	87/74	89/74	92/75	93/80	92/80	92/81	93/82	99/82	99/83	101/83	88/74	90/76	93/78	97/81	97/80	98/79	99/80	100/81	101/83
	600	V ₁ [m ³ /min]	18,3	21,1	24,1	32,3	37,3	39,9	42,3	47,9	50,8	54,1	18,3	25,1	28,9	33,7	38,7	44,3	50,9	53,2
t ₂ [°C]		85	83	81	79	77	77	77	76	76	75	89	84	82	80	79	78	77	77	76
nG [rpm]		1475	1650	1840	2350	2660	2820	2970	3320	3500	3710	1160	1475	1650	1870	2100	2360	2660	2770	2960
nM [rpm]		2945	2950	2950	2955	2955	2970	2970	2970	2970	2970	2945	2950	2940	2955	2955	2970	2970	2970	1480
P _k [kW]		25,2	28,4	32,0	42,3	49,1	52,8	56,3	59,7	63,6	68,3	26,1	33,6	37,8	43,3	49,2	56,1	64,1	67,2	72,5
P _{mot} [kW]		30	37	37	55	55	75	75	75	75	90	30	37	45	55	55	75	75	75	90
Motor size		200 L	200 L	200 L	250 M	250 M	280 S	280 S	280 S	280 S	280 M	200 L	200 L	225 M	250 M	250 M	280 S	280 S	280 S	280 M
Lp(A)[dB]w _b .H.w.H.		88/75	90/75	92/76	94/81	93/81	94/82	95/82	100/83	101/85	103/85	89/75	92/77	94/80	97/82	97/80	98/78	100/80	101/81	102/83
700		V ₁ [m ³ /min]	17,9	20,7	23,7	31,7	36,6	39,4	41,8	44,7	50,3	53,7	17,7	24,5	28,2	33,4	38,4	43,8	49,9	52,5
	t ₂ [°C]	98	95	93	89	88	87	87	86	85	85	103	96	94	92	90	89	87	87	86
	nG [rpm]	1475	1650	1840	2340	2640	2820	2970	3150	3500	3710	1160	1470	1640	1880	2110	2360	2640	2760	2980
	nM [rpm]	2950	2950	2940	2955	2970	2970	2970	2970	2970	2950	2940	2955	2970	2970	2970	1480	1480	1485	
	P _k [kW]	29,1	32,8	36,9	48,4	55,7	60,3	64,2	64,6	73,0	78,2	30,3	38,8	43,5	50,4	57,1	64,6	73,2	76,9	83,8
	P _{mot} [kW]	37	37	45	55	75	75	75	75	90	90	37	45	55	75	75	90	90	90	110
	Motor size	200 L	200 L	225 M	250 M	280 S	280 S	280 S	280 S	280 M	280 M	200 L	225 M	250 M	280 S	280 S	280 S	280 M	280 M	315 S
	Lp(A)[dB]w _b .H.w.H.	89/75	90/76	92/78	95/83	95/83	95/83	96/83	100/83	102/86	106/86	90/76	93/78	95/80	98/82	98/81	99/79	100/80	101/81	103/83
	800	V ₁ [m ³ /min]											17,2	24,1	27,6	32,9	37,8	43,1	49,6	52,2
t ₂ [°C]												118	109	106	103	101	99	98	97	96
nG [rpm]												1160	1475	1640	1880	2110	2350	2650	2770	2980
nM [rpm]												2940	2955	2955	2970	2970	1480	1485	1485	1485
P _k [kW]												34,5	44,2	49,5	57,2	64,8	72,8	83,1	87,2	94,6
P _{mot} [kW]												45	55	55	75	75	90	110	110	110
Motor size												225 M	250 M	250 M	280 S	280 S	280 M	315 S	315 S	315 S
Lp(A)[dB]w _b .H.w.H.												92/77	97/79	98/81	100/83	100/82	101/81	102/81	102/82	103/84
900		V ₁ [m ³ /min]											16,7	23,6	27,4	32,4	37,4	42,4	49,1	51,7
	t ₂ [°C]											133	122	119	115	112	110	108	108	107
	nG [rpm]											1160	1475	1650	1880	2110	2340	2650	2770	2980
	nM [rpm]											2940	2955	2970	2970	1480	1480	1485	1485	1485
	P _k [kW]											38,7	49,6	55,8	64,0	72,4	80,9	92,6	97,2	105
	P _{mot} [kW]											45	55	75	75	90	90	110	110	132
	Motor size											225 M	250 M	280 S	280 S	280 M	280 M	315 S	315 S	315 M
	Lp(A)[dB]w _b .H.w.H.											92/78	97/80	99/82	101/83	100/82	100/81	102/82	102/82	104/84
	1000	V ₁ [m ³ /min]											23,3	26,9	31,9	36,3	42,1	48,6	51,2	55,8
t ₂ [°C]												135	131	127	124	121	119	118	117	
nG [rpm]												1485	1650	1880	2080	2350	2650	2770	2980	
nM [rpm]												2970	2970	1480	1480	1485	1485	1485	1485	
P _k [kW]												55,3	61,7	70,8	78,8	89,8	102	107	116	
P _{mot} [kW]												75	75	90	90	110	132	132	132	
Motor size												280 S	280 S	280 M	280 M	315 S	315 M	315 M	315 M	
Lp(A)[dB]w _b .H.w.H.												97/82	99/83	102/83	101/83	100/82	102/82	103/83	104/84	

Lower differential pressures on request
GM 50 L from 45 m³/min - accessories DN 200

Performance data for air ($p_1 = 1,0 \text{ bar}$, $t_1 = 20 \text{ }^\circ\text{C}$, $\rho = 1,189 \text{ kg/m}^3$) overpressure

Ap [mbar]	Blower size	GM 80 L / DN 250										GM 90 S / DN 250									
300	\dot{V}_1 [m³/min]	22,8	33,1	37,9	46,4	56,2	64,2	73,5	78,7	83,9	33,7	43,8	54,2	58,7	66,6	70,8	80,3	85,7	90,3		
	t_2 [°C]	53	51	50	49	48	48	48	47	47	50	49	48	48	48	48	47	47	47		
	nG [rpm]	975	1310	1465	1740	2060	2320	2620	2790	2960	978	1220	1470	1580	1770	1870	2100	2230	2340		
	nM [rpm]	1460	1465	1465	1470	1470	1475	1480	1480	1480	1465	1465	1470	1470	1475	1475	1480	1480	1480		
	Pk [kW]	15,8	21,7	24,5	29,9	36,7	42,8	50,5	55,2	60,3	21,3	27,1	33,7	36,8	42,6	45,8	53,7	58,4	62,7		
	P _{mot} [kW]	18,5	30	30	37	45	55	75	75	75	30	30	45	45	55	55	75	75	75		
	Motor size	180 M	200 L	200 L	225 S	225 M	250 M	280 S	280 S	280 S	200 L	200 L	225 M	225 M	250 M	250 M	280 S	280 S	280 S		
	Lp(A)[dB]w/o.H./w.H.	86/73	89/74	90/74	94/77	97/77	96/77	97/78	98/78	101/79	88/71	91/72	94/75	94/75	100/80	101/81	100/79	99/78	100/78		
	400	\dot{V}_1 [m³/min]	21,7	32,0	36,9	45,2	56,0	63,4	72,7	77,6	82,8	32,8	43,1	53,3	57,7	64,7	70,1	79,3	84,7	89,2	
t_2 [°C]		66	62	61	60	58	58	57	57	57	62	60	58	58	58	57	57	57	56		
nG [rpm]		975	1310	1470	1740	2090	2330	2630	2790	2960	980	1230	1475	1580	1750	1880	2100	2230	2340		
nM [rpm]		1465	1470	1470	1470	1475	1480	1480	1480	1480	1470	1470	1475	1475	1480	1480	1480	1480	1480		
Pk [kW]		20,8	28,4	32,2	38,8	48,1	55,0	64,3	69,6	75,5	28,1	35,9	44,1	47,8	54,1	59,1	68,2	73,9	78,9		
P _{mot} [kW]		30	37	37	45	55	75	75	90	90	37	45	55	55	75	75	90	90	90		
Motor size		200 L	225 S	225 S	225 M	250 M	280 S	280 S	280 M	280 M	225 S	225 M	250 M	250 M	280 S	280 M	280 M	280 M	280 M		
Lp(A)[dB]w/o.H./w.H.		86/73	90/75	92/76	95/77	96/78	96/78	98/78	99/79	102/80	89/72	92/72	95/75	97/76	100/80	101/81	100/79	100/78	100/77		
500		\dot{V}_1 [m³/min]	20,7	31,0	35,9	44,3	55,4	62,4	72,0	76,6	82,1	31,8	42,2	52,6	56,3	63,8	69,2	79,2	83,7	89,0	
	t_2 [°C]	81	74	73	71	69	68	67	67	67	74	71	69	68	68	67	67	66	66		
	nG [rpm]	975	1310	1470	1740	2100	2330	2640	2790	2970	980	1230	1480	1570	1750	1880	2120	2230	2380		
	nM [rpm]	1465	1470	1470	1475	1480	1480	1480	1485	1485	1470	1475	1480	1480	1480	1485	1485	1485	1485		
	Pk [kW]	25,8	35,1	39,7	47,8	59,2	67,0	78,2	83,9	91,1	34,9	44,4	54,5	58,3	66,2	72,1	83,7	89,3	97,2		
	P _{mot} [kW]	30	45	45	55	75	75	90	110	110	45	55	75	75	90	110	110	110	110		
	Motor size	200 L	225 M	225 M	250 M	280 S	280 S	280 M	315 S	315 S	225 M	250 M	280 S	280 S	280 S	280 M	315 S	315 S	315 S		
	Lp(A)[dB]w/o.H./w.H.	87/74	92/75	93/77	95/78	95/79	96/78	99/78	101/80	103/82	89/73	92/73	96/75	97/76	101/80	102/81	101/79	100/78	101/77		
	600	\dot{V}_1 [m³/min]	20,0	30,1	35,2	43,7	54,5	61,9	72,0	75,7	81,3	31,1	41,4	51,7	55,5	63,0	68,4	78,3	82,9	88,5	
t_2 [°C]		96	87	85	82	80	79	77	77	77	86	82	80	79	78	77	76	76	76		
nG [rpm]		980	1310	1475	1750	2100	2340	2670	2790	2970	982	1230	1480	1570	1750	1880	2120	2230	2390		
nM [rpm]		1470	1475	1475	1480	1480	1480	1485	1485	1485	1475	1480	1480	1480	1480	1485	1485	1485	1485		
Pk [kW]		31,0	41,8	47,4	57,1	70,0	79,3	93,0	98,2	106	41,8	52,9	64,7	69,1	78,3	85,1	98,4	105	114		
P _{mot} [kW]		37	55	55	75	90	90	110	110	132	55	75	75	90	90	110	110	132	132		
Motor size		225 S	250 M	250 M	280 S	280 M	280 M	315 S	315 S	315 M	250 M	280 S	280 S	280 M	280 M	315 S	315 S	315 M	315 M		
Lp(A)[dB]w/o.H./w.H.		89/73	91/75	93/76	95/79	95/79	96/79	99/80	101/81	103/83	90/74	93/73	97/75	98/76	102/80	103/82	101/80	101/79	102/78		
700		\dot{V}_1 [m³/min]	19,1	29,3	34,5	42,9	53,6	61,0	71,2	74,9	80,1	30,3	40,6	51,0	54,7	62,6	67,6	77,5	82,1	87,5	
	t_2 [°C]	112	101	97	94	91	89	88	87	87	99	94	91	90	88	88	87	86	86		
	nG [rpm]	980	1310	1480	1750	2100	2340	2670	2790	2960	982	1230	1480	1570	1760	1880	2120	2230	2360		
	nM [rpm]	1470	1475	1480	1480	1480	1485	1485	1485	1480	1475	1480	1480	1480	1485	1485	1485	1480	1480		
	Pk [kW]	36,0	48,6	55,2	66,1	80,8	91,4	107	113	121	48,6	61,4	75,0	80,0	91,0	98,2	113	120	129		
	P _{mot} [kW]	45	55	75	75	90	110	132	132	160	55	75	90	90	110	110	132	160	160		
	Motor size	225 M	250 M	280 S	280 S	280 M	315 S	315 M	315 M	315 M	250 M	280 S	280 M	280 M	315 S	315 S	315 M	315 M	315 M		
	Lp(A)[dB]w/o.H./w.H.	88/73	91/75	93/76	95/79	95/81	97/80	101/80	102/81	104/83	91/74	94/74	98/77	99/78	103/82	104/83	102/80	102/80	103/79		
	800	\dot{V}_1 [m³/min]										29,7	39,9	50,4	54,0	61,9	67,3	76,8	81,0	86,8	
t_2 [°C]											112	106	102	101	99	98	97	96	96		
nG [rpm]											985	1230	1485	1570	1760	1890	2120	2220	2360		
nM [rpm]											1480	1480	1485	1485	1485	1485	1480	1480	1480		
Pk [kW]											55,6	69,9	85,5	90,9	103	112	128	135	145		
P _{mot} [kW]											75	90	110	110	132	132	160	160	160		
Motor size											280 S	280 M	315 S	315 S	315 M	315 M	315 M	315 M	315 M		
Lp(A)[dB]w/o.H./w.H.											91/74	95/75	99/78	100/79	104/84	105/84	104/81	103/81	104/81		
900		\dot{V}_1 [m³/min]										29,0	39,2	49,8	53,3	61,2	66,6	76,1	80,3	86,1	
	t_2 [°C]										126	118	113	112	110	109	107	106	106		
	nG [rpm]										985	1230	1485	1570	1760	1890	2120	2220	2360		
	nM [rpm]										1480	1480	1485	1485	1485	1480	1480	1485	1485		
	Pk [kW]										62,4	78,4	95,8	102	115	125	142	150	161		
	P _{mot} [kW]										75	90	110	132	132	160	160	200	200		
	Motor size										280 S	280 M	315 S	315 M	315 M	315 M	315 M	315 M	315 M		
	Lp(A)[dB]w/o.H./w.H.										91/74	95/75	98/78	100/79	104/84	105/84	104/82	103/82	104/81		
	1000	\dot{V}_1 [m³/min]										38,5	49,1	52,7	60,5	65,9	75,5	79,6	85,5		
t_2 [°C]											131	125	124	121	120	118	117	116			
nG [rpm]											1230	1485	1570	1760	1890	2120	2220	2360			
nM [rpm]											1485	1485	1485	1480	1480	1485	1485	1485			
Pk [kW]											86,9	106	113	128	138	157	166	178			
P _{mot} [kW]											110	132	132	160	160	200	200	200			
Motor size											315 S	315 M	315 M	315 M	315 M	315 M	315 M	315 M			
Lp(A)[dB]w/o.H./w.H.											95/75	98/77	100/79	104/84	105/85	104/83	104/82	104/81			

Lower differential pressures on request

Performance data for air ($p_1 = 1,0 \text{ bar}$, $t_1 = 20 \text{ }^\circ\text{C}$, $\rho = 1,189 \text{ kg/m}^3$) overpressure

Δp [mbar]	Blower size	GM 130 L / DN 300									GM 150 S / DN 300							
300	\dot{V}_1 [m³/min]	47,8	62,9	78,0	82,2	94,3	102	115	131	134	77,3	94,4	102	116	122	132	147	152
	t_2 [°C]	51	50	49	49	48	48	48	47	47	49	48	48	48	48	47	47	47
	nG [rpm]	980	1230	1480	1550	1750	1880	2100	2350	2400	982	1170	1250	1410	1480	1580	1750	1800
	nM [rpm]	1470	1470	1480	1480	1480	1480	1480	1485	1485	1475	1480	1480	1480	1480	1485	1485	1485
	Pk [kW]	32,0	40,8	50,5	53,3	61,9	67,9	78,7	92,1	95,0	48,4	59,4	64,5	75,3	80,3	87,8	102	106
	P_{mot} [kW]	37	45	75	75	75	75	90	110	110	55	75	75	90	90	110	132	132
	Motor size	225 S	225 M	280 S	280 S	280 S	280 S	280 M	315 S	315 S	250 M	280 S	280 S	280 M	280 M	315 S	315 M	315 M
	Lp(A)[dB]w/o.H./w.H.	93/75	95/77	101/79	100/79	101/80	101/80	103/81	104/82	104/82	95/79	97/79	97/79	97/80	98/80	99/80	101/81	101/81
	400	\dot{V}_1 [m³/min]	46,2	61,2	76,3	80,5	93,2	100	115	130	132	75,8	92,6	101	114	121	130	146
t_2 [°C]		63	61	59	59	58	58	57	57	57	59	58	58	57	57	57	57	57
nG [rpm]		982	1230	1480	1550	1760	1880	2120	2370	2400	985	1170	1260	1410	1485	1580	1760	1800
nM [rpm]		1475	1480	1480	1480	1480	1485	1485	1485	1485	1480	1480	1485	1485	1485	1485	1480	1480
Pk [kW]		41,9	53,2	65,4	68,9	80,1	86,8	101	117	119	63,4	77,1	84,2	96,6	103	112	129	133
P_{mot} [kW]		55	75	75	90	90	110	132	132	132	75	90	110	110	132	132	160	160
Motor size		250 M	280 S	280 S	280 M	280 M	315 S	315 M	315 M	315 M	280 S	280 M	315 S	315 S	315 M	315 M	315 M	315 M
Lp(A)[dB]w/o.H./w.H.		93/76	96/78	102/80	101/79	102/80	103/81	103/81	105/83	106/83	96/79	97/79	98/79	98/80	98/80	99/80	101/81	102/82
500		\dot{V}_1 [m³/min]	44,8	60,8	74,7	86,2	91,6	98,9	113	128	130	74,2	91	100	113	120	127	144
	t_2 [°C]	76	72	70	69	69	68	67	67	67	70	69	68	67	67	67	66	66
	nG [rpm]	985	1250	1480	1670	1760	1880	2120	2370	2400	985	1170	1270	1410	1485	1570	1760	1800
	nM [rpm]	1480	1480	1480	1485	1485	1480	1480	1480	1480	1480	1485	1485	1485	1480	1480	1485	1485
	Pk [kW]	52,0	66,8	80,3	92,0	97,8	106	122	141	143	78,3	94,8	104	118	126	135	156	160
	P_{mot} [kW]	75	75	90	110	110	132	160	160	160	90	110	132	132	160	160	200	200
	Motor size	280 S	280 S	280 M	315 S	315 S	315 M	315 M	315 M	315 M	280 M	315 S	315 M	315 M	315 M	315 M	315 M	315 M
	Lp(A)[dB]w/o.H./w.H.	92/77	97/79	102/80	101/80	103/81	104/81	104/81	107/83	107/83	97/79	97/79	98/79	98/79	98/80	99/81	101/82	102/82
	600	\dot{V}_1 [m³/min]	43,4	59,4	73,6	84,8	90,2	97,5	112	119	126	72,7	89,5	101	110	118	126	143
t_2 [°C]		89	84	81	80	79	79	77	77	77	82	80	78	78	77	77	76	76
nG [rpm]		985	1250	1485	1670	1760	1880	2120	2230	2360	985	1170	1300	1400	1485	1570	1760	1800
nM [rpm]		1480	1480	1485	1485	1485	1480	1480	1485	1485	1485	1485	1480	1480	1485	1485	1485	1485
Pk [kW]		61,9	79,3	95,5	109	116	125	144	153	164	93,2	113	127	138	148	158	182	188
P_{mot} [kW]		75	90	110	132	132	160	160	200	200	110	132	160	160	200	200	250	250
Motor size		280 S	280 M	315 S	315 M	315 M	315 M	315 M	315 M	315 M	315 S	315 M	315 M	315 M	315 M	315 M	315 L	315 L
Lp(A)[dB]w/o.H./w.H.		94/78	97/80	104/82	102/82	104/83	105/83	107/83	107/83	107/84	99/79	99/79	99/79	99/80	100/80	100/82	102/83	102/83
700		\dot{V}_1 [m³/min]										71,4	88,2	96,3	109	117	125	142
	t_2 [°C]										93	91	89	88	88	87	86	86
	nG [rpm]										985	1170	1260	1400	1485	1580	1760	1800
	nM [rpm]										1485	1480	1480	1485	1485	1485	1485	1485
	Pk [kW]										108	130	141	159	170	183	209	215
	P_{mot} [kW]										132	160	160	200	200	250	250	250
	Motor size										315 M	315 M	315 M	315 M	315 M	315 L	315 L	315 L
	Lp(A)[dB]w/o.H./w.H.										100/80	100/80	100/80	100/80	101/81	101/82	102/83	102/83
	800	\dot{V}_1 [m³/min]										70,2	88,8	96,0	108	116	124	140
t_2 [°C]											105	101	100	99	98	97	96	96
nG [rpm]											985	1190	1270	1400	1488	1580	1760	1800
nM [rpm]											1480	1485	1485	1485	1485	1485	1490	1490
Pk [kW]											123	151	162	180	193	207	235	242
P_{mot} [kW]											160	200	200	200	250	250	315	315
Motor size											315 M	315 M	315 M	315 M	315 L	315 L	315 L	315 L
Lp(A)[dB]w/o.H./w.H.											101/80	100/80	100/80	100/80	102/82	102/83	102/83	103/84
900		\dot{V}_1 [m³/min]										69	87,6	94,9	107	115	123	139
	t_2 [°C]										118	113	111	110	109	108	106	106
	nG [rpm]										985	1190	1270	1400	1488	1580	1760	1800
	nM [rpm]										1480	1485	1485	1485	1485	1490	1490	1490
	Pk [kW]										138	169	181	202	216	231	262	269
	P_{mot} [kW]										160	200	200	250	250	315	315	315
	Motor size										315 M	315 M	315 M	315 L	315 L	315 L	315 L	315 L
	Lp(A)[dB]w/o.H./w.H.										102/81	101/80	101/80	101/81	102/83	103/84	103/84	103/84
	1000	\dot{V}_1 [m³/min]										68,4	86,5	93,8	106	114	122	138
t_2 [°C]											130	124	123	121	120	118	117	116
nG [rpm]											990	1190	1270	1400	1488	1580	1760	1800
nM [rpm]											1485	1485	1485	1485	1490	1490	1490	1490
Pk [kW]											154	187	200	223	238	255	289	296
P_{mot} [kW]											200	250	250	250	315	315	355	355
Motor size											315 M	315 L	315 L	315 L	315 L	315 L	355 M	355 M
Lp(A)[dB]w/o.H./w.H.											103/82	102/81	102/80	102/81	103/84	104/84	103/84	104/84

Lower differential pressures on request
Higher intake volume flows on request

Performance data for air ($p_1 = 1,0 \text{ bar}$, $t_1 = 20 \text{ }^\circ\text{C}$, $\rho = 1,189 \text{ kg/m}^3$) overpressure

Δp [mbar]	Blower size	GM 220 L / DN 400								GM 240 S / DN 400							
300	V_1 [m³/min]	104	119	133	153	177	199	215	227	112	128	146	156	167	192	213	246
	t_2 [°C]	49	49	49	48	48	47	47	47	49	49	48	48	48	47	47	47
	nG [rpm]	930	1040	1150	1300	1480	1650	1770	1860	730	820	920	980	1040	1180	1300	1485
	nM [rpm]	1480	1480	1485	1485	1480	1480	1485	1485	1480	1485	1485	1485	1485	1480	1485	1485
	Pk [kW]	67,2	77,0	87,3	102	122	141	156	168	72,6	83,5	96,4	105	113	136	157	195
	P_{mot} [kW]	75	90	110	132	160	160	200	200	90	110	110	132	132	160	200	250
	Motor size	280 S	280 M	315 S	315 M	315 M	315 M	315 M	315 M	280 M	315 S	315 S	315 M	315 M	315 M	315 M	315 L
	Lp(A)[dB]w.o.H.w.H.	94/76	95/76	96/76	97/77	100/79	102/80	103/82	104/82	97/76	97/76	97/77	98/77	97/77	98/77	99/78	101/80
	400	V_1 [m³/min]	102	116	130	150	175	196	212	224	109	125	143	153	164	189	210
t_2 [°C]		60	59	59	58	57	57	57	57	60	59	58	58	58	57	57	56
nG [rpm]		930	1040	1150	1300	1485	1650	1770	1860	730	820	920	980	1040	1180	1300	1490
nM [rpm]		1485	1485	1485	1480	1485	1485	1485	1485	1485	1485	1480	1480	1480	1485	1485	1490
Pk [kW]		87,6	99,8	112	131	155	178	195	209	94,2	108	124	134	144	171	196	241
P_{mot} [kW]		110	110	132	160	200	200	250	250	110	132	160	160	160	200	250	315
Motor size		315 S	315 S	315 M	315 M	315 M	315 M	315 L	315 L	315 S	315 M	315 M	315 M	315 M	315 M	315 L	315 L
Lp(A)[dB]w.o.H.w.H.		95/76	95/77	96/77	98/78	100/80	102/81	104/82	105/83	98/77	98/77	98/78	98/78	98/78	98/78	99/79	103/81
500		V_1 [m³/min]	99,1	114	128	148	172	194	210	221	106	122	140	151	162	186	208
	t_2 [°C]	72	70	69	68	68	67	67	66	71	70	69	68	68	67	67	66
	nG [rpm]	930	1040	1150	1300	1485	1650	1770	1860	730	820	920	980	1040	1180	1300	1490
	nM [rpm]	1485	1480	1480	1485	1485	1485	1490	1490	1485	1480	1485	1485	1485	1485	1490	1490
	Pk [kW]	108	123	138	159	187	214	234	250	116	132	151	163	175	206	234	285
	P_{mot} [kW]	132	160	160	200	250	250	315	315	132	160	200	200	200	250	315	315
	Motor size	315 M	315 M	315 M	315 M	315 L	315 L	315 L	315 L	315 M	315 M	315 M	315 M	315 M	315 L	315 L	315 L
	Lp(A)[dB]w.o.H.w.H.	96/77	96/77	97/77	98/78	100/80	102/81	104/83	106/84	98/78	98/78	99/79	99/79	98/78	98/79	100/80	104/83
	600	V_1 [m³/min]	96,8	111	126	146	170	192	207	219	104	120	138	149	159	184	206
t_2 [°C]		83	82	80	79	78	77	76	76	83	81	80	79	78	77	76	76
nG [rpm]		930	1040	1150	1300	1485	1650	1770	1860	730	820	920	980	1040	1180	1300	1490
nM [rpm]		1480	1480	1485	1485	1485	1490	1490	1490	1480	1485	1485	1485	1485	1490	1490	1490
Pk [kW]		128	145	163	188	220	250	273	290	137	156	178	192	206	241	273	329
P_{mot} [kW]		160	160	200	250	250	315	315	355	160	200	200	250	250	315	315	400
Motor size		315 M	315 M	315 M	315 L	315 L	315 L	315 L	355 M	315 M	315 M	315 M	315 L	315 L	315 L	315 L	355 M
Lp(A)[dB]w.o.H.w.H.		97/77	97/78	97/77	98/78	100/80	102/81	105/83	106/85	99/79	99/79	100/80	100/80	100/80	101/80	102/81	105/84
700		V_1 [m³/min]									102	118	136	147	157	182	204
	t_2 [°C]									94	92	90	90	89	87	87	85
	nG [rpm]									730	820	920	980	1040	1180	1300	1490
	nM [rpm]									1485	1485	1485	1485	1490	1490	1490	1490
	Pk [kW]									159	181	205	221	237	276	311	373
	P_{mot} [kW]									200	200	250	250	315	315	355	500
	Motor size									315 M	315 M	315 L	315 L	315 L	315 L	355 M	355 L
	Lp(A)[dB]w.o.H.w.H.									100/80	101/80	101/81	102/81	102/81	103/82	104/83	106/85
	800	V_1 [m³/min]									100	116	134	145	155	180	202
t_2 [°C]										107	104	102	101	100	98	97	95
nG [rpm]										730	820	920	980	1040	1180	1300	1490
nM [rpm]										1485	1485	1490	1490	1490	1490	1490	1490
Pk [kW]										181	205	233	250	268	311	350	417
P_{mot} [kW]										200	250	315	315	315	355	400	500
Motor size										315 M	315 L	315 L	315 L	315 L	355 M	355 M	355 L
Lp(A)[dB]w.o.H.w.H.										100/81	102/81	103/83	103/83	104/83	105/84	106/85	107/86

Lower differential pressures on request
Higher intake volume flows on request

Dimensions – DELTA BLOWER – GM 3 S – LU 41.01 and LU 41.02

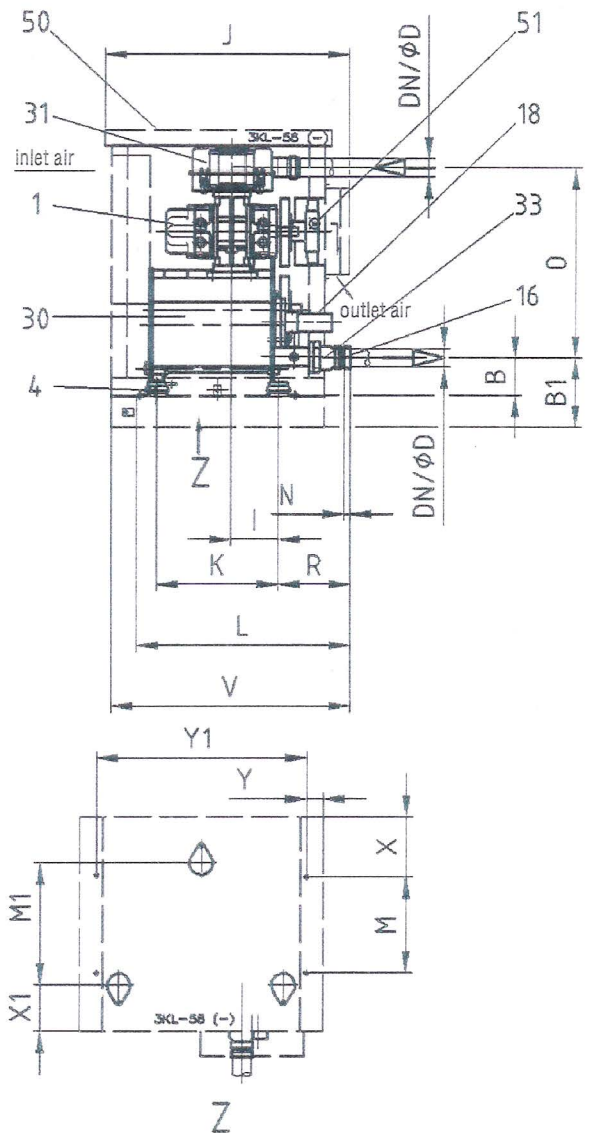
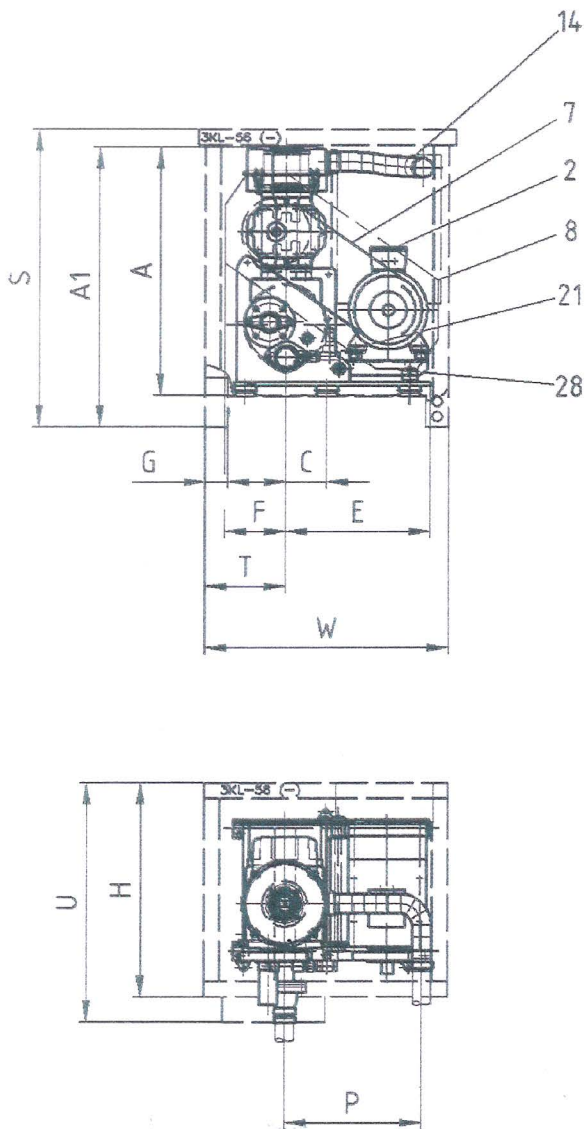

- 1 positive displacement blower
- 2 electric motor
- 4 anti-vibration mountings
- 7 belt drive
- 8 belt guard (only in case of installation without acoustic hood)
- 14 flexible pipe connection suction side (extra price)
- 16 flexible connection discharge side
- 18 pressure relief valve

- 21 start-up unloading device (accessory)
- 28 hinged motor plate
- 30 base frame
- 31 filter silencer
- 33 connection housing with integrated non-return valve
- 50 acoustic hood
- 51 fan
- 71 pressure gauge (accessory)
- 75 maintenance indicator (accessory)

type	A	A ₁	B	B ₁	C	DN/φD	E	F	G	H	I	J	K	L	M	M ₁	N	O	P	R	S	T	V	W	U	X	X ₁	Y	Y ₁	Weight without acoustic hood	Weight with acoustic hood
3 S	815	920	123	228	135	50 / φ 60.3	475	201	75	700	155	805	400	699	320	400	20	637	450	235	978	265	785	800	782	190	150	55	690	165 kg	215 kg

Dimensions expressed (in mm), not binding

Weight without motor

Dimensions – DELTA BLOWER – GM 4 S to GM 25 S – LU 41.01 and LU 41.02

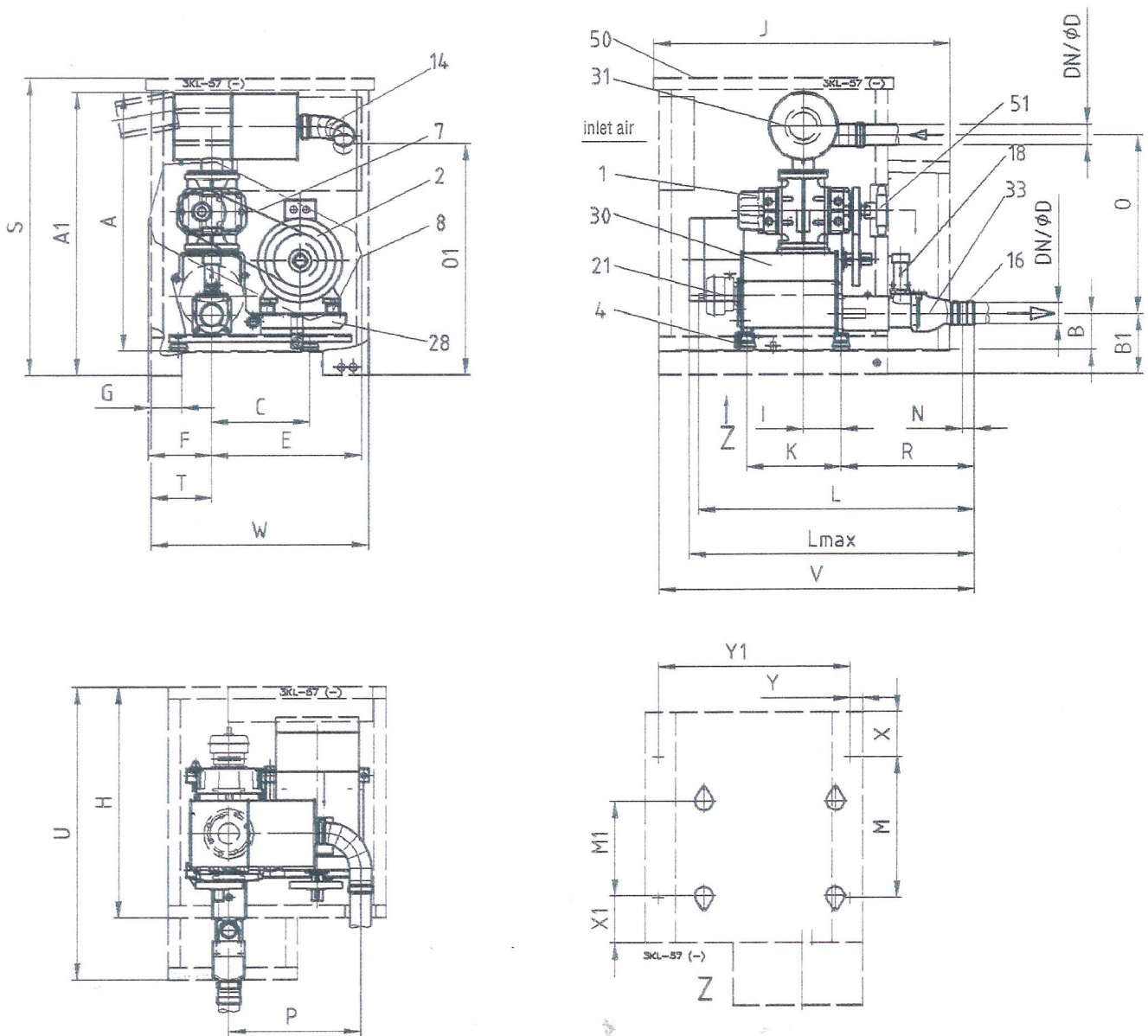

- 1 positive displacement blower
- 2 electric motor
- 4 anti-vibration mountings
- 7 belt drive
- 8 belt guard (only in case of installation without acoustic hood)
- 14 flexible pipe connection suction side (extra price)
- 16 flexible connection discharge side
- 18 pressure relief valve
- 21 start-up unloading device (accessory)
- 28 hinged motor plate
- 30 base frame
- 31 filter silencer
- 33 connection housing with integrated non-return valve
- 50 acoustic hood
- 51 fan
- 71 pressure gauge (accessory)
- 75 maintenance indicator (accessory)

type	A	A ₁	B	B ₁	C	DN/ø D	DN ₁ /ø D ₁	E	F	G	H	I	J	K	L	L _{max}	M	M ₁	N	O	O ₁	P	R	S	T	V	W	U	X	X ₁	Y	Y ₁	Weight without acoustic hood	Weight with acoustic hood
4 S	1020	1125	153	258	416	80/ø 88.9	80/ø 88.9	639	269	130	975	160	1260	400	1172	1211	595	400	52	762	720	559	567	1265	258	1342	925	1237	190	200	55	815	206 kg	277 kg
7 L	1020	1125	153	258	416	80/ø 88.9	80/ø 88.9	639	269	130	975	160	1260	400	1172	1211	595	400	52	762	720	559	567	1265	258	1342	925	1237	190	200	55	815	227 kg	316 kg
10 S	1101	1206	153	258	416	80/ø 88.9	80/ø 88.9	639	269	130	975	160	1260	400	1172	1211	595	400	52	762	801	559	567	1265	258	1342	925	1237	190	200	55	815	258 kg	347 kg
10 S	1333	1438	189	294	505	100/ø 114.3	100/ø 114.3	818	300	140	1100	185	1436	500	-	1419	720	500	45	971	1265	650	640	1500	375	1516	1250	1412	190	224	55	1140	339 kg	556 kg
15 L	1333	1438	189	294	505	100/ø 114.3	100/ø 114.3	818	300	140	1100	185	1436	500	-	1419	720	500	45	971	1265	650	640	1500	375	1516	1250	1412	190	224	55	1140	348 kg	571 kg
25 S	1322	1428	189	294	505	125/ø 139.7	150/ø 168.3	818	315	155	1100	185	1436	500	-	1538	720	500	70	971	1265	650	775	1500	375	1651	1250	1412	190	224	55	1140	415 kg	638 kg

Dimensions expressed (in mm), not binding

Weight without motor

Dimensions – DELTA BLOWER – GM 30 L to GM 60 S – LU 41.01 and LU 41.02

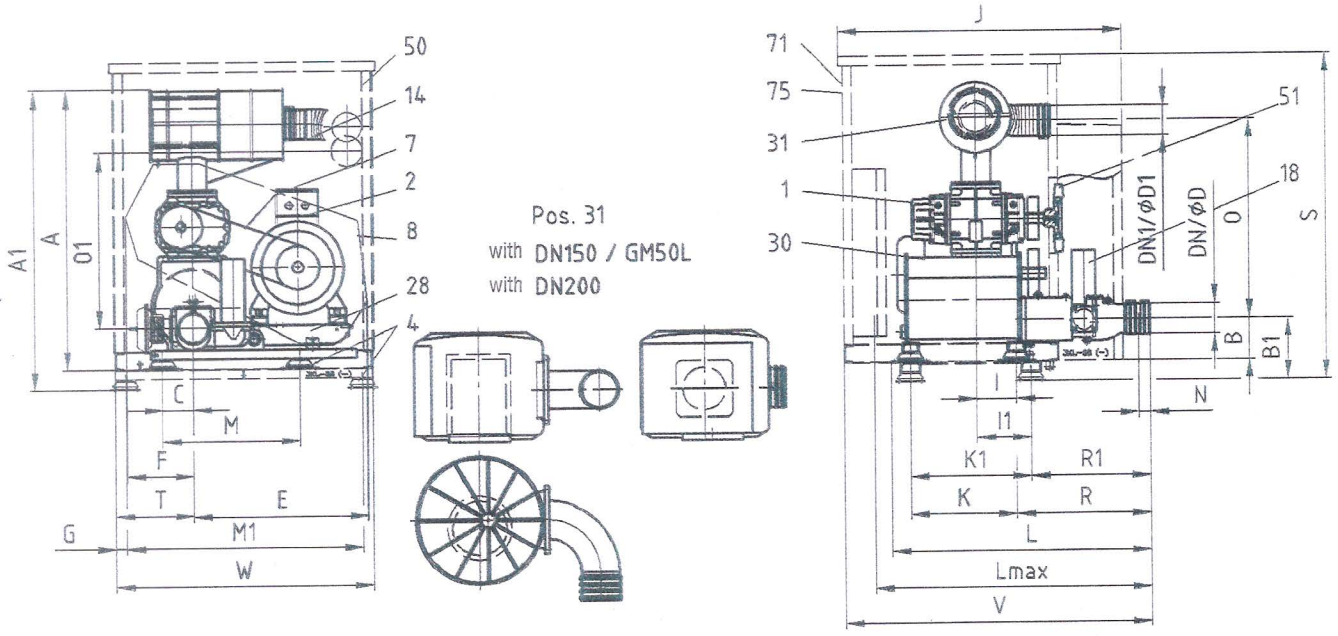

Pos. 31
with DN150 / GM50L
with DN200

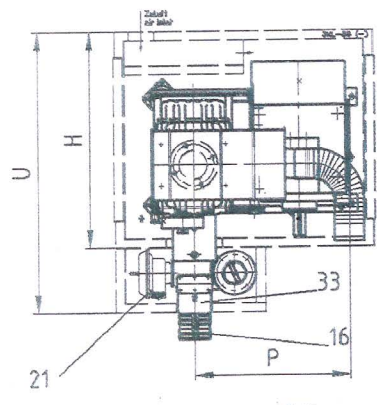

- 1 positive displacement blower
- 2 electric motor
- 4 anti-vibration mountings
- 7 belt drive
- 8 belt guard (only in case of installation without acoustic hood)
- 14 flexible pipe connection suction side (extra price)
- 16 flexible connection discharge side
- 18 pressure relief valve
- 21 start-up unloading device (accessory)
- 28 hinged motor plate
- 30 base frame
- 31 filter silencer
- 33 connection housing with integrated non-return valve
- 50 acoustic hood
- 51 fan
- 71 pressure gauge (accessory)
- 75 maintenance indicator (accessory)

type	A	A ₁	B	B ₁	C	DN / ø D	DN ₁ / ø D ₁	E	F	G	H	I	I ₁	J	K	K ₁	L	L _{max}	M	M ₁	N	O	O ₁	P	R	R ₁	S	T	V	W	U	Weight without acoustic hood	Weight with acoustic hood
30 L	1590	1708	238	356	180	150 / ø 168.3	150 / ø 168.3	1016	390	60	1250	230	314	1648	615	700	1508	1584	800	1380	70	1141	1161	905	780	695	1900	455	1783	1500	1625	611 kg	907 kg
35 S	1630	1748	238	356	180	150 / ø 168.3	150 / ø 168.3	1016	390	60	1250	230	314	1648	615	700	1508	1584	800	1380	70	1186	1161	905	780	695	1900	455	1783	1500	1625	666 kg	971 kg
50 L	1692	1810	238	356	180	150 / ø 168.3	200 / ø 219.1	1016	390	60	1250	368	341	1648	615	700	1508	1584	800	1380	70	1019	1119	703	780	695	1900	455	1783	1500	1625	770 kg	1070 kg
50 L	1615	1745	320	450	320	200 / ø 219.1	200 / ø 219.1	1035	440	60	1460	283	293	1917	731	741	1740	1921	820	1480	70	1024	1024	673	927	428	2100	493	2098	1600	1895	985 kg	1365 kg
60 S	1715	1845	320	450	320	200 / ø 219.1	200 / ø 219.1	1035	440	60	1460	283	293	1917	731	741	1740	1921	820	1480	70	1124	1117	673	927	428	2100	493	2098	1600	1895	1110 kg	1490 kg

Dimensions expressed (in mm), not binding

Weight without motor

Dimensions – DELTA BLOWER – GM 80 L to GM 150 S – LU 41.01 and LU 41.02

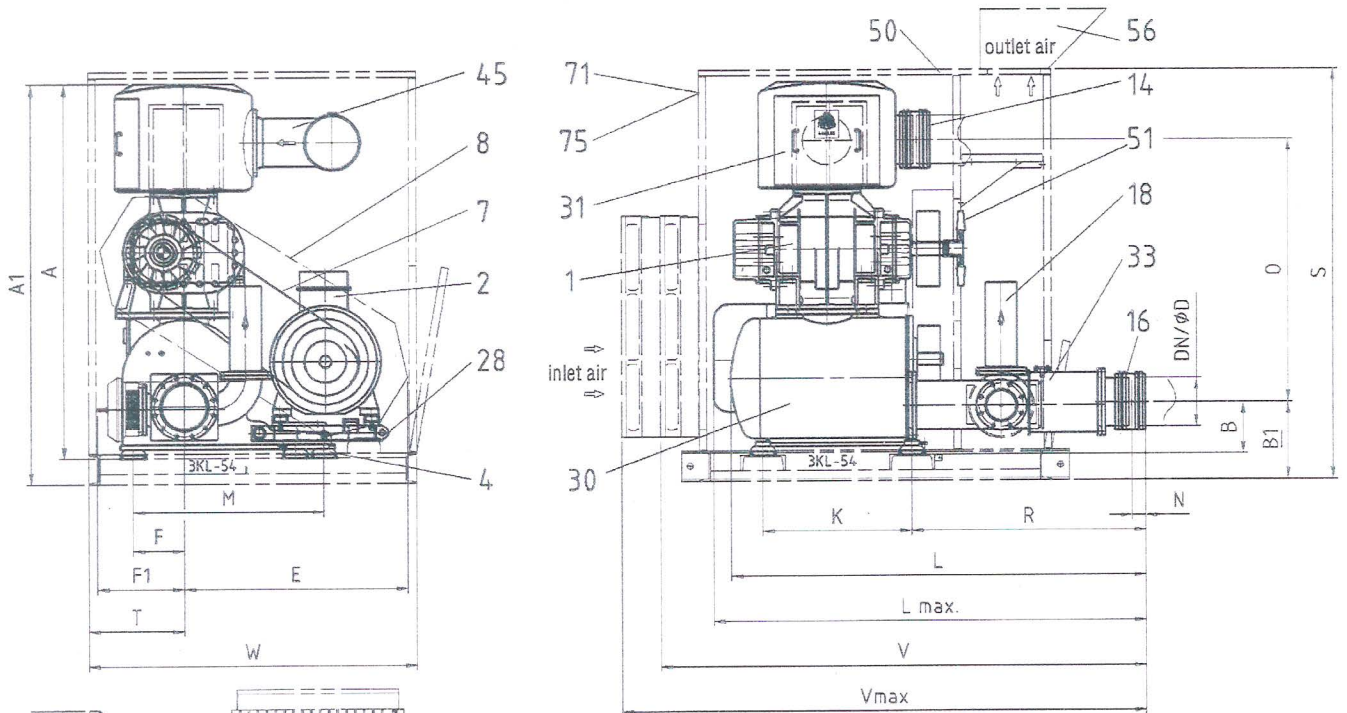

- 1 positive displacement blower
- 2 electric motor
- 4 anti-vibration mountings
- 7 belt drive
- 8 belt guard (only in case of installation without acoustic hood)
- 14 flexible pipe connection suction side (extra price)
- 16 flexible connection discharge side
- 18 pressure relief valve
- 21 start-up unloading device (accessory)
- 28 hinged motor plate
- 30 base frame
- 31 filter silencer
- 33 connection housing with integrated non-return valve
- 45 pipe connection suction side (extra price)
- 50 acoustic hood
- 51 fan
- 56 shelter (accessory)
- 71 pressure gauge (accessory)
- 75 maintenance indicator (accessory)

type	A	A ₁	B	B ₁	DN / ø D	DN ₁ / ø D ₁	E	F	F ₁	K	L	L _{max}	M	N	O	P	R	S	T	V	V _{max}	W	U	Weight without acoustic hood	Weight with acoustic hood
80 L	1885	2015	326	456	250 / ø 273	250 / ø 273	1078	330	485	741	2090	2286	880	90	1236	696	1258	2200	495	2614	2964	1600	2110	1610 kg	2395 kg
90 S	2015	2145	326	456	250 / ø 273	250 / ø 273	1087	330	485	741	2090	2286	880	90	1366	696	1258	2200	495	2614	2964	1600	2110	1750 kg	2535 kg
130 L	2335	2505	344	514	300 / ø 323.9	300 / ø 323.9	1491	340	560	995	2765	3230	1270	90	1585	990	1558	2740	640	3237	3587	2190	2590	2567 kg	4182 kg
150 S	2505	2675	344	514	300 / ø 323.9	300 / ø 323.9	1491	340	560	995	2765	3230	1270	90	1755	990	1558	2740	640	3237	3587	2190	2590	2812 kg	4427 kg

Dimensions expressed (in mm), not binding

Weight without motor

Dimensions – DELTA BLOWER – GM 220 L and GM 240 S – LU 41.01

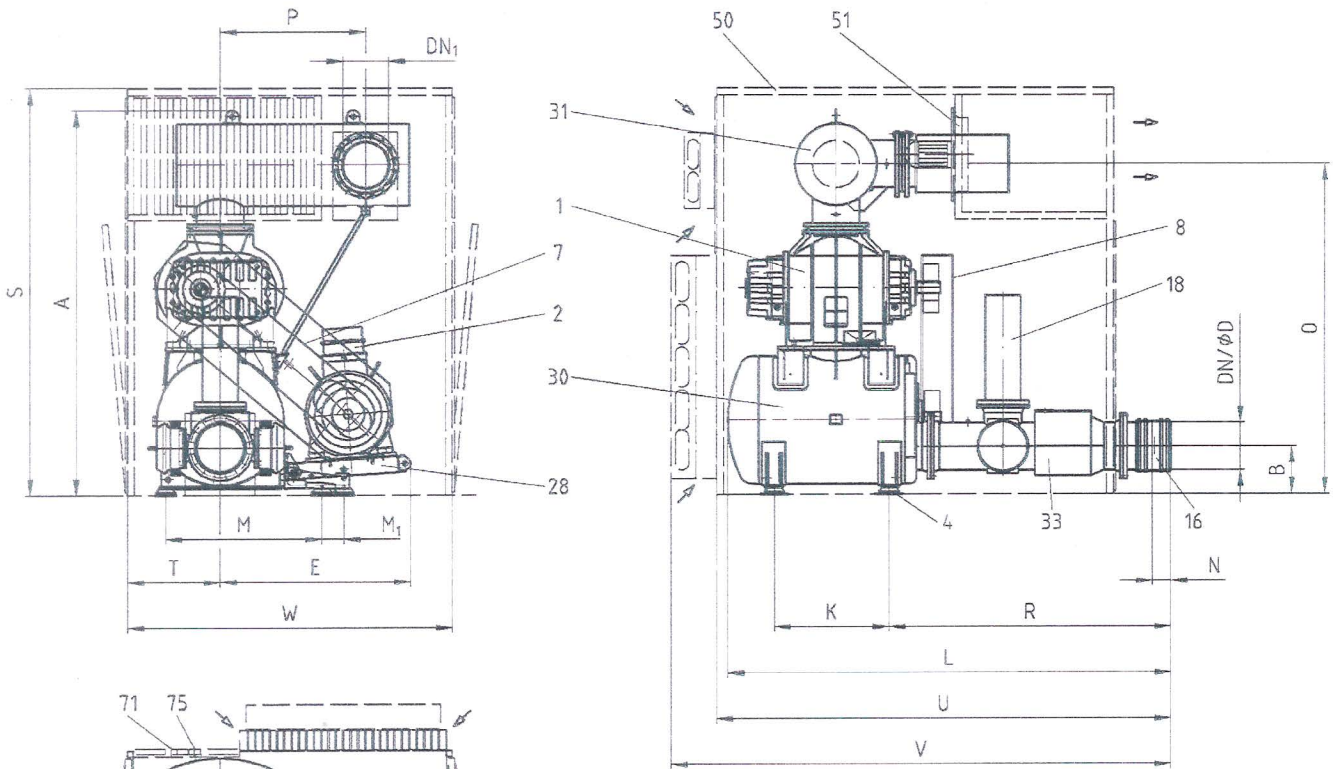

- 1 positive displacement blower
- 2 electric motor
- 4 anti-vibration mountings
- 7 belt drive
- 8 belt guard
- 16 flexible connection discharge side
- 18 pressure relief valve
- 21 start-up unloading device (accessory)
- 28 hinged motor plate
- 30 base frame
- 31 filter/silencer
- 33 connection housing with integrated non-return valve
- 50 acoustic hood
- 51 fan
- 71 pressure gauge (accessory)
- 75 maintenance indicator (accessory)

type	A	B	DN / ø D	DN ₁	E	K	L	M	M ₁	N	O	P	R	S	T	V	W	U	Weight without acoustic hood	Weight with acoustic hood
220 L	3110	410	400 / ø 406.4	400	1644	990	3813	1345	190	160	2639	1250	2421	3500	800	4304	2800	3910	4981 kg	8240 kg
240 S	3310	410	400 / ø 406.4	400	1644	990	3813	1345	190	160	2639	1250	2421	3500	800	4304	2800	3910	5371 kg	8630 kg

Dimensions expressed (in mm), not binding

Weight without motor



Aerzener Maschinenfabrik GmbH

Reherweg 28 · 31855 Aerzen / Germany – P.O. Box 1163 · 31849 Aerzen / Germany
 Phone + 49 51 54 / 8 10 · Fax + 49 51 54 / 8 11 91 · <http://www.aerzener.com> · E-mail: info@aerzener.de

